



# The Perfect Temperature For Your Wine

Quality, Design and Innovation

WKb 4112



# LIEBHERR

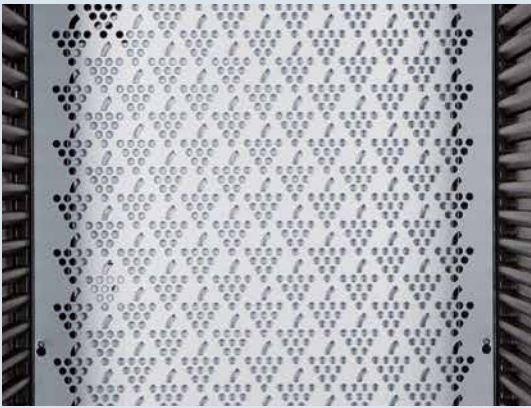

**Optimum humidity:** Liebherr wine cabinets guarantee an optimum humidity and this ensured the corks are supple in place whilst still allowing the wine to breathe in its maturing process.



**LED lighting:** The tinted glass door provides not only a perfect UV protection, but also an optimum glance at wine. The integrated LED lighting ensures a pleasant illumination of the complete interior.



**Presentation shelf:** The presentation shelf, equipped with wooden angles, is ideal for presenting wine and storing open bottles safely. Up to 6 bottles can be set upright on the flexible shelf. In addition further bottles can be stored lying down either behind or at the side.

*Note: Whilst every effort is made to ensure all specifications and information in this flyer are accurate, Liebherr reserves the right to make changes without notification. Where actual appliance measurements, specifications, and ratings are crucial, we recommend that the actual appliance installation instructions that accompany each appliance be checked. Liebherr will not be liable for any loss.*

The **WKb 4112** wine storage cabinet provides the same conditions as in a wine cellar, making it ideal for the long-term storage of fine wines. Its temperature range can be adjusted from +5°C to +20°C for storing exclusive wines at the perfect temperature. The tinted insulating glass door also provides protection against UV radiation and helps to preserve the quality of the wines. Untreated wooden shelves are designed for the safe and appropriate storage of Bordeaux bottles. Our integrated activated carbon filter absorbs odours from the ambient air and prevents the taste of fine wines from being impaired. Other optional accessories<sup>1</sup> are also available for added flexibility.

**WKb 4112** LED Wine  
 Barrique

°Energy consumption (kWh/yr)   24hr	°178   0.487
Bottle capacity (750ml Bordeaux)	168
Safety glass door	•
Control system   Display	Buttons   Digital
Digital temperature display	External
Tinted glazed door	Double
Temperature zones	1
Temperature range (°C) Min   Max °C	5   20
Suitable for ambient temperature Min   Max°C	10   43
Interior light	Vertical LED
Beech wood shelves	5
Presentation shelf   Base shelves	Integrated   1
Recirculated air cooling   Fresh air supply via activated charcoal filter	•   1
Child proof lock (control panel)	•
Handle design	Black plastic
Key lock   Label holders	•   •
Temp alarm   Door open warning signal	•   •
Door hinge	Right, reversible
Gross weight (kg)   Net weight (kg)	86   78
Voltage (V)   Rated Current (A)	220-240   1.0
Made In	Malaysia

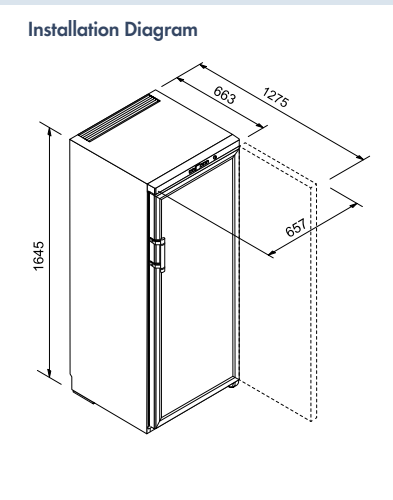

Activated Charcoal Filter  
 Part no.: 3988129100

° = Measurements taken at +25°C ambient and +12°C interior temperature tested by Liebherr Germany (not to Australian standards).

<sup>1</sup> Optional accessories: Activated Charcoal Filter (Part no: 3988129100)