

ECBN 8872

Integrated fridge-freezer with
BioFresh and NoFrost

LIEBHERR

Fully Integrated

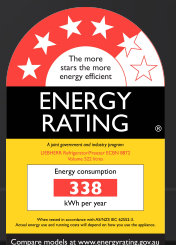

Fully Integrated

LIEBHERR

ECBN 8872

Integrated fridge-freezer with BioFresh and NoFrost



← 91 → 203
↑
↓



Type	Fixed door / Built-in appliance for integrated use
Energy consumption (kWh/yr)/Star rating	338 / 4,5
Total volume	522 l ¹
Volume	BioFresh compartment: 70.6 l / Freezer compartment: 160 l
Noise output	39 dB(A)
Climate rating	SN-T (+10 °C to +43 °C)
Frequency / voltage	50/60 Hz / 220-240 V~
Connection Rating	2.5 A 189.4 W
Aperture dimensions in cm (h / w / d)	203.2-207.2 / 91.5 / min. 63.5
Controls	
Type of Control	MagicEye, touch electronic Digital temperature display for fridge, BioFresh and freezer compartments
Door alarm	acoustic
Alarm in case of malfunction	visual and acoustic
Fridge compartment	
Forced air system	PowerCooling
Door interior	Comfort GlassLine storage shelves with bottle holder, egg tray
Bottle shelf	Integrated bottle shelf
Interior light	LED light column on both sides and LED ceiling lighting LED BioFresh lighting
BioFresh-Safes	2 BioFresh safes on telescopic rails set variably to either HydroSafe or DrySafe
Freezer compartment	
Interior light	LED lighting
Number of drawers	2 drawers on telescopic rails
IceMaker	with fixed 3/4" water connection
Ice cube capacity in 24 hours	1.4 kg
Ice cube stock	2.7 kg
Freezing capacity in 24 hours	9.5 kg
Features	
Door hinges	Door hinge left fixed/right fixed
Replaceable door seal	yes
EAN-Nr.	9005382271254

¹ In accordance with Regulation EU 2019/2016 we indicate the total volume to the nearest integer (rounded off) and the volume of the frozen compartments and refrigeration compartments to one place after the decimal point.

Features



BioFresh

Sensitive food also stays fresh for a long time in BioFresh safes. For example, a temperature of close to 0 °C means the Meat & Dairy safe provides the ideal storage conditions for meat or fresh milk. There's also higher humidity in the Fruit & Vegetable safe thanks to the airtight closure – perfect for fruit and vegetables. The best part is: all optimal adjustments are made in the factory.



DuoCooling

DuoCooling uses two completely separate refrigeration circuits to ensure no air is exchanged between the fridge and freezer compartments. The food neither dries out nor is odour transferred. This means throwing less away, shopping less often, but saving more and greater enjoyment.

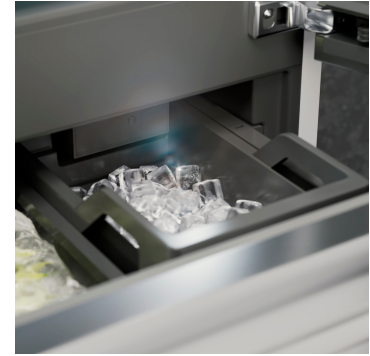

IceMaker with fixed water connection

Are there any ice cubes left? The IceMaker means you never have to ask. With the IceMaker with fixed water connection, the water comes directly from the tap. The MaxIce function allows you to produce up to 1.5 kg of ice cubes a day. The versatile ice compartment separator lets you choose the amount of ice cubes you want to store; easy and just as you like it.



NoFrost

When you open your freezer, you want to see frozen food – and certainly not ice and frost. NoFrost protects the freezer compartment from unwanted icing, which consumes a lot of energy and can be expensive. NoFrost means no more tedious and time-consuming defrosting of the freezer compartment, more time for other things – and saving money.



SuperFrost

Want to freeze your fresh food in a way that preserves vitamins? Simply activate SuperFrost – and the freezer compartment will increase its cooling capacity. In this way, the temperature remains constant when you place in unfrozen food. SuperFrost is also energy-saving: if you don't switch off the function manually, it automatically deactivates itself after 65 hours.



Door alarm

The audible door alarm alerts the user if the door has been open for longer than 60 seconds for safe protection of the food.

Technical drawing

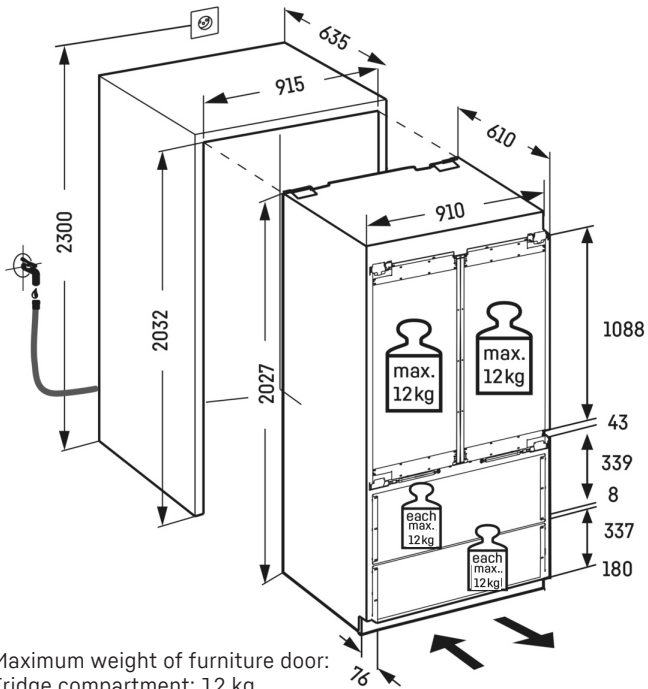

Maximum weight of furniture door:
Fridge compartment: 12 kg
Freezer compartment: 12 kg

Products and their details are staged for advertising purposes. Whilst every effort is made to ensure all specifications and information in this flyer are accurate, Liebherr reserves the right to make changes without notification. Where actual appliance measurements, specifications, and ratings are crucial, we recommend that the actual appliance installation instructions that accompany each appliance be checked. Liebherr will not be liable for any damage. (18.07.2024)

