LH 60 Port Litronic

LIEBHERR

Material handling machine



Generation
6

Operating weight
59,900–81,300 kg*

* Without attachment

Engine
Stage V
Stage IIIA (compliant)
Tier 4 Final
Electric

Performance

Power plus speed –
Redefined performance

Economy

Good investment –
Savings for long-term

Reliability

Durability and sustainability –
Quality down to the last detail

Comfort

Perfection at a glance –
When technology is comfortable

Maintainability

Efficiency bonus –
Even with maintenance and service



LH 60 M Port Litronic

Operating weight

59,900–67,000 kg*

Engine

190 kW / 258 HP (Diesel)

180 kW (Electric)

Stage V

Stage IIIA (compliant)

Tier 4 Final

Electric

System performance

322 kW (Diesel)

312 kW (Electric)

* Without attachment



LH 60 C Port Litronic

Operating weight
65,200–71,600 kg*

Engine
190 kW / 258 HP (Diesel)
180 kW (Electric)
Stage V
Stage IIIA (compliant)
Tier 4 Final
Electric

System performance
322 kW (Diesel)
312 kW (Electric)

LH 60 M High Rise Port Litronic

Operating weight
71,300–80,300 kg*

Engine
190 kW / 258 HP (Diesel)
180 kW (Electric)
Stage V
Stage IIIA (compliant)
Tier 4 Final
Electric

System performance
322 kW (Diesel)
312 kW (Electric)

LH 60 C High Rise Port Litronic

Operating weight
72,300–81,300 kg*

Engine
190 kW / 258 HP (Diesel)
180 kW (Electric)
Stage V
Stage IIIA (compliant)
Tier 4 Final
Electric

System performance
322 kW (Diesel)
312 kW (Electric)

Technical data

Diesel engine

Rating per ISO 9249	190 kW (258 HP) at 1,800 RPM
Model	Liebherr D944
Type	4 cylinder in-line
Bore / Stroke	130 / 150 mm
Displacement	8.0 l
Engine operation	4-stroke diesel Common-Rail Turbo-charged and after-cooled Reduced emissions
Air cleaner	Dry-type air cleaner with pre-cleaner, primary and safety elements
Engine idling	Sensor controlled
Electrical system	
Voltage	24 V
Batteries	2 x 180 Ah / 12 V
Alternator	Three-phase current 28 V / 140 A
Stage V	
Harmful emissions values	According to regulation (EU) 2016/1628
Emission control	Liebherr-SCR Filter technology
Fuel tank	521 l
Urea tank	65 l
Stage IIIA (compliant)	
Harmful emissions values	In accordance with ECE-R.96 Power Band H
Fuel tank	521 l
Tier 4 Final	
Harmful emissions values	In accordance with 40CFR1039 (EPA) / 13CCR (CARB)
Emission control	Liebherr-SCR technology
Fuel tank	521 l
Urea tank	65 l

Electric motor

Rating	180 kW at 1,800 RPM
Type	Three-phase squirrel cage motor
Secondary electric motor	Electric motor auxiliary equipment (air-conditioning compressor, alternator 24 V) 15 kW
Electrical system energy supply	Frequency converter fed drive system Heavy-duty version
Supply voltage	
Low voltage	380 V, 400 V
Frequency	50 / 60 Hz
Engine idling	Sensor controlled
Electrical system	Battery-assisted Control system, lighting, diagnostics system
Voltage	24 V
Batteries	2 x 135 Ah / 12 V
Alternator	Three-phase current 28 V / 140 A

Deviating parameters of the power supply system must always be clarified with Liebherr-Hydraulikbagger GmbH.

Cooling system

Diesel engine	Water-cooled Compact cooling system consisting cooling unit for water, hydraulic oil and charge air with stepless thermostatically controlled fan
Electric motor	Air-cooled Cooling system for hydraulic oil with an infinitely variable, thermostatically controlled fan drive system

Hydraulic controls

Power distribution	Via control valves with integrated safety valves, simultaneous actuation of chassis and equipment. Swing drive in separate closed circuit
Servo circuit	
Equipment and swing	With electro-hydraulic pilot control and proportional joystick levers
Chassis mobile	Electro-proportional via foot pedal
Chassis crawler	With electric proportionally functioning foot pedals or adjusted with plugable levers
Additional functions	Via switch or electro-proportional foot pedals
Proportional control	Proportionally acting transmitters on the joysticks for additional hydraulic functions

Hydraulic system

Hydraulic pump	
For equipment and travel drive	2 Liebherr axial piston variable displacement pumps (double construction)
Max. flow	2 x 302 l/min.
Max. pressure	350 bar
For swing drive	Reversible axial piston variable displacement pump, closed-loop circuit
Max. flow	199 l/min.
Max. pressure	370 bar
Hydraulic pump regulation and control	2 circuit Liebherr-Synchron-Comfort-system (LSC) with electronic engine speed sensing regulation, pressure and flow compensation, automatic oil flow optimizer
Hydraulic tank	265 l
Hydraulic system	910 l
Filtration	2 main return filters with integrated partial micro filtration (5 µm)
MODE selection	Adjustment of engine and hydraulic performance via a mode pre-selector to match application, e.g. for especially economical and environmentally friendly operation or for maximum material handling and heavy-duty jobs
S (Sensitive)	Mode for precision work and lifting through very sensitive movements
E (Eco)	Mode for especially economical and environmentally friendly operation
P (Power)	Mode for high performance with low fuel consumption
P+ (Power-Plus)	Mode for highest performance and for very heavy duty applications, suitable for continuous operation
Engine speed and performance setting	Stepless alignment of engine output and hydraulic power via engine speed
Option	Tool Control: 20 pre-adjustable pump flows and pressures for add-on attachments

Swing drive

Drive	Liebherr axial piston motor in a closed system, Liebherr planetary reduction gear
Swing ring	Liebherr, sealed race ball bearing swing ring, internal teeth
Swing speed	0-6.5 RPM stepless
Swing torque	118 kNm
Holding brake	Wet multi-disc (spring applied, pressure released)
Option	Slewing gear brake Comfort

Cab

Cab	Safety cab structure with individual windscreens or featuring a slide-in subpart under the ceiling, work headlights integrated in the ceiling, a door with a sliding window (can be opened on both sides), large stowing and depositing possibilities, shock-absorbing suspension, sound damping insulating, tinted laminated safety glass, separate shades for the sunroof window and windscreen
High Rise	Deviating from standard: safety cab structure with fixed built-in front and roof window made from impact-resistant laminated safety glass
Operator's seat Comfort	Air cushioned operator's seat with 3D-adjustable armrests, headrest, lap belt, seat heater, adjustable seat cushion inclination and length, lockable horizontal suspension, automatic weight adjustment, adjustable suspension stiffness, pneumatic lumbar vertebrae support and passive seat climatisation with active coal
Operator's seat Premium (Option)	In addition to operator's seat comfort: active electronic weight adjustment (automatic readjustment), pneumatic low frequency suspension and active seat climatisation with active coal and ventilator
Arm consoles	Joysticks with control consoles and swivel seat, folding left control console
Operation and displays	Large high-resolution operating unit, self-explanatory, colour display with touchscreen, video-compatible, numerous setting, control and monitoring options, e.g. air conditioning control, fuel consumption respectively energy consumption, machine and attachment parameters
Air-conditioning	
Diesel engine	Automatic air-conditioning, recirculated air function, fast de-icing and demisting at the press of a button, air vents can be operated via a menu; recirculated air and fresh air filters can be easily replaced and are accessible from the outside; heating-cooling unit, designed for extreme outside temperatures, sensors for solar radiation, inside and outside temperatures
Electric motor	In addition to diesel engine: stationary air conditioning function with external climate condenser – controlled by a weekly timer
Refrigerant	R134a
Global warming potential	1,430
Quantity at 25 °C*	1,400–2,000 g (Diesel) 1,500–2,100 g (Electric)
CO ₂ equivalent*	2.002–2.860 t (Diesel) 2.145–3.003 t (Electric)
Vibration emission**	
Hand / arm vibrations	< 2.5 m/s ²
Whole-body vibrations	< 0.5 m/s ²
Measuring inaccuracy	According with standard EN 12096:1997

Equipment

Type	Weight-optimised design for bulk and general cargo handling at optimal handling capacity. Complex and stable mountings of equipment and cylinders
Hydraulic cylinders	Liebherr cylinders with special sealing and guide system and, depending on cylinder type, shock absorption
Energy recovering cylinder	Liebherr gas cylinder with special sealing and control system
Bearings	Sealed, low maintenance

* depending on configuration

** for risk assessment according to 2002/44/EC see ISO/TR 25398:2006

Undercarriage

Mobile	
Versions	Standard, High Rise
Drive	One axle drive per drive axle with Liebherr axial piston motor and functional brake valve on both sides
Travel speed	0–12.0 km/h stepless
Joystick steering	0– 4.0 km/h stepless (creeper speed) (Diesel) 0– 3.7 km/h stepless (creeper speed) (Electric) 0–10.0 km/h stepless (High Rise) 0– 3.5 km/h stepless (creeper speed) (High Rise)
Driving operation	Automotive driving using accelerator pedal, cruise control function: storage of variable accelerator pedal positions
Axles	70 t / 90 t drive axles (LH 60 M / LH 60 M High Rise); manual or automatic hydraulically controlled front axle oscillation lock
Service brake	Two circuit travel brake system with accumulator; disc brake
Holding brake	Wet multi-disc (spring applied, pressure released)
Stabilization	4 point outriggers
Crawler	
Versions	SW, High Rise
Drive	Liebherr compact planetary reduction gear with Liebherr axial piston motor per side of undercarriage
Travel speed	0–4.0 km/h stepless 0–2.8 km/h stepless (creeper speed) 0–4.0 km/h stepless (High Rise) 0–2.5 km/h stepless (creeper speed) (High Rise)
Brake	Functional brake valves on both sides
Holding brake	Wet multi-disc (spring applied, pressure released)
Track pads	Triple grouser, flat
Tracks	Sealed and greased

Complete machine

Lubrication	Liebherr central lubrication system for uppercarriage and equipment, automatically Liebherr central lubrication system for undercarriage, automatically
Mobile (Option)	
Steps system	Safe and durable access system with anti-slip steps; main components hot-galvanised
Noise emission	
ISO 6396 (Stage V)	70 dB(A) = L _{PA} (inside cab)
2000/14/EC (Stage V)	103 dB(A) = L _{WA} (surround noise)
ISO 6396 (Stage IIIA compliant)	not specified
2000/14/EC (Stage IIIA compliant)	not specified
ISO 6396 (Tier 4 Final)	70 dB(A) = L _{PA} (inside cab)
2000/14/EC (Tier 4 Final)	103 dB(A) = L _{WA} (surround noise)
ISO 6396 (Electric)	70 dB(A) = L _{PA} (inside cab)
2000/14/EC (Electric)	103 dB(A) = L _{WA} (surround noise)

LH 60 M – Dimensions

Port

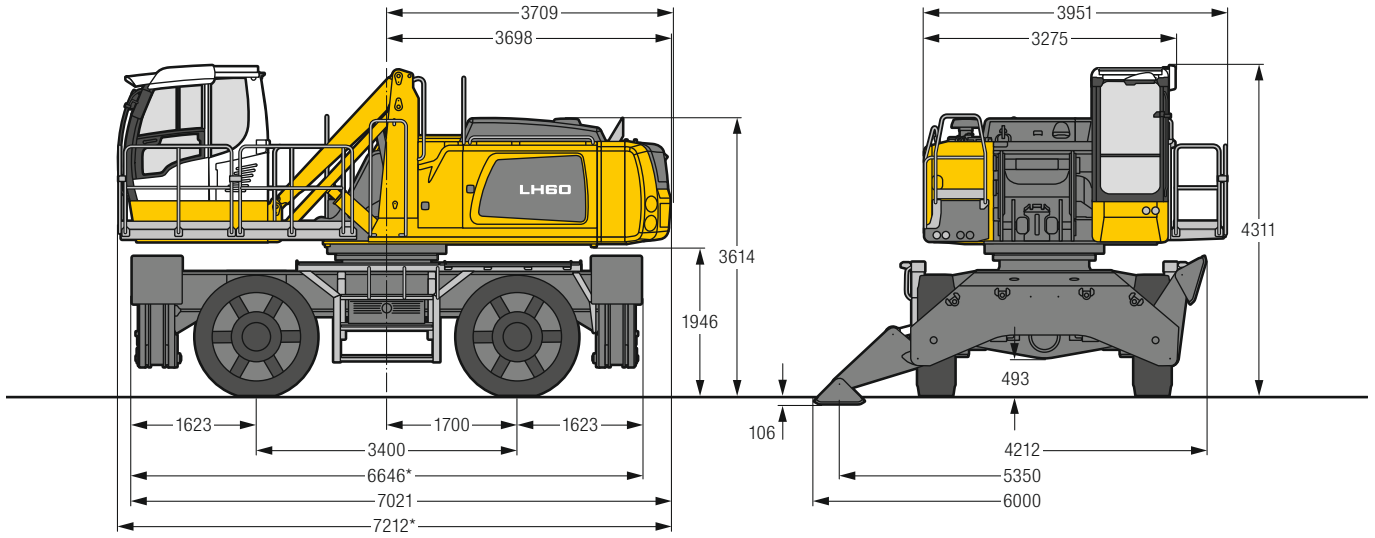

* For electric machines, the length of the machine is increased accordingly by the trailing cable / cable reel system. Detailed dimensions are available on request.

LH 60 M – Choice of cab elevation

Cab elevation LFC (rigid elevation)

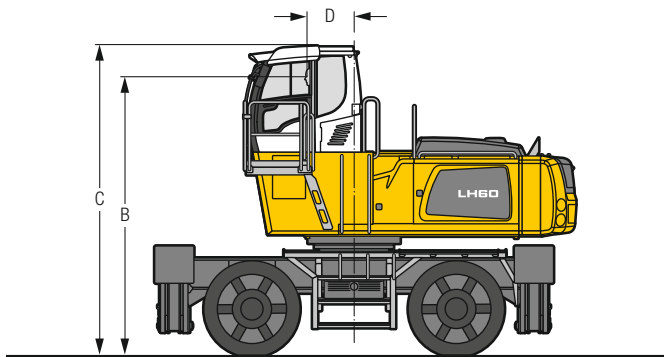

Increase type	LFC 120
Height	1,200 mm
B	4,646 mm
C	5,159 mm
D	788 mm

A rigid cab elevation has a fixed eye level height. For a lower transport height, the shell of the cab can be removed and replaced by a transport device. The dimension C is in this machine design for all rigid cab elevations 4,263 mm.

Cab elevation LHC (hydraulic elevation)

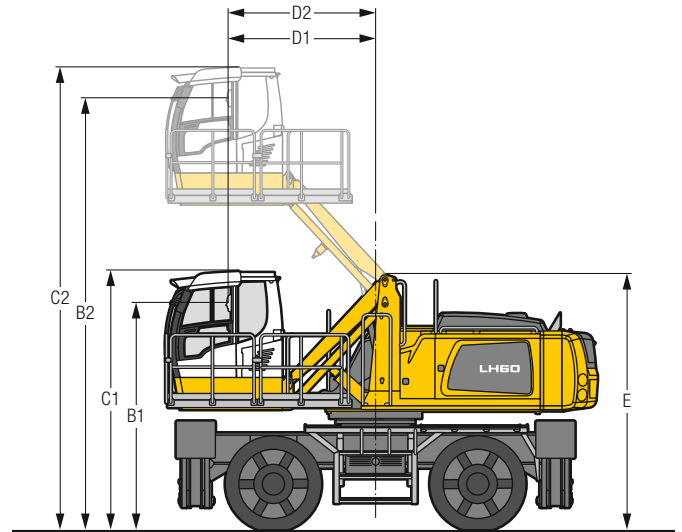

Increase type	LHC 255	LHC 340-35
B1	3,436 mm	3,797 mm
B2	5,983 mm	7,213 mm
C1	3,949 mm	4,311 mm
C2	6,496 mm	7,727 mm
D1	1,343 mm	2,457 mm
D2	1,469 mm	2,457 mm
E	3,851 mm	4,251 mm

The hydraulically adjustable cab allows the driver, that he can choose his field of view freely and at any time within the stroke.

Tyres 18.00-25

LH 60 C – Dimensions

Port

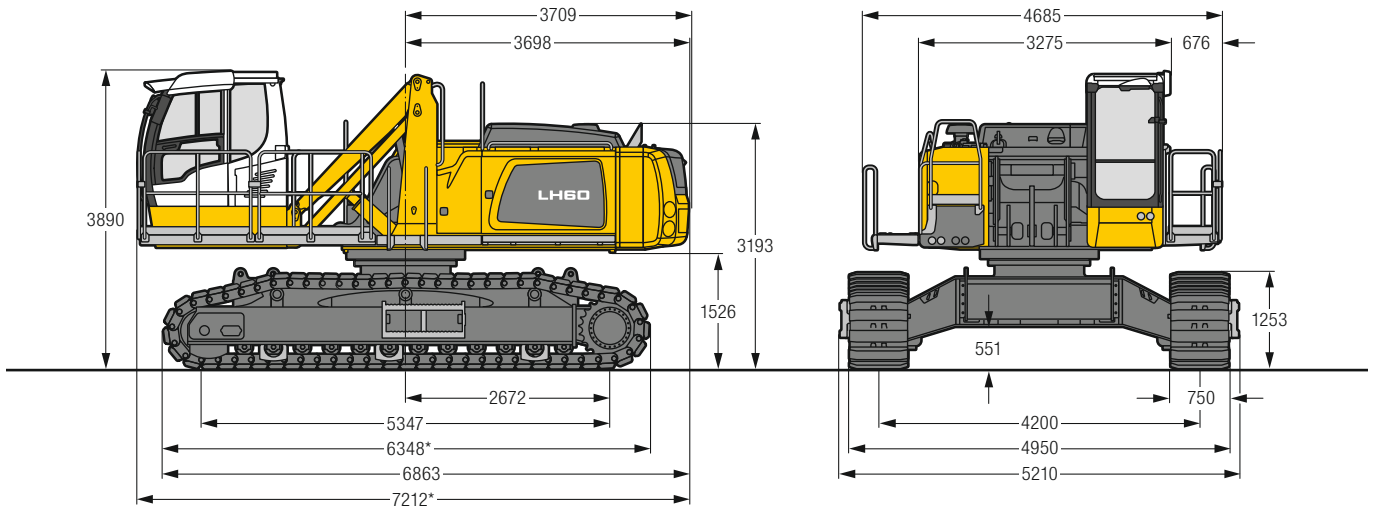

* For electric machines, the length of the machine is increased accordingly by the trailing cable / cable reel system. Detailed dimensions are available on request.

LH 60 C – Choice of cab elevation

Cab elevation LFC (rigid elevation)

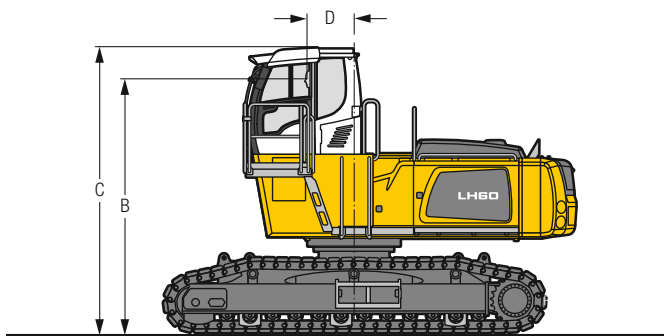

Increase type	LFC 120
Height	1,200 mm
B	4,228 mm
C	4,741 mm
D	788 mm

A rigid cab elevation has a fixed eye level height. For a lower transport height, the shell of the cab can be removed and replaced by a transport device. The dimension C is in this machine design for all rigid cab elevations 3,845 mm.

Cab elevation LHC (hydraulic elevation)

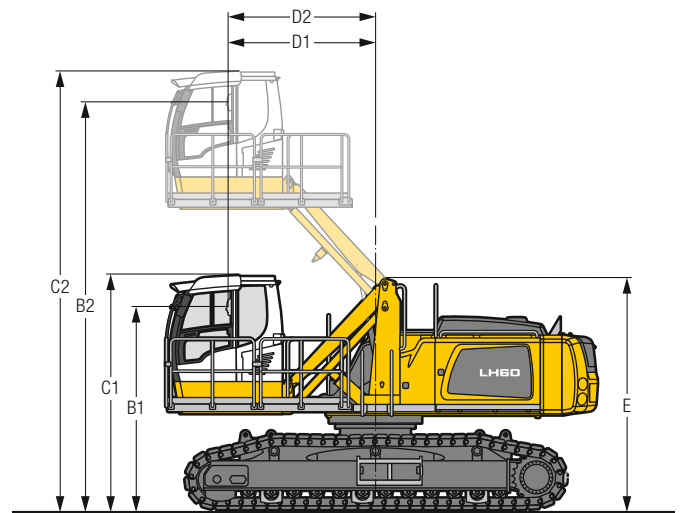

Increase type	LHC 255	LHC 340-35
B1	3,025 mm	3,377 mm
B2	5,572 mm	6,793 mm
C1	3,539 mm	3,890 mm
C2	6,086 mm	7,306 mm
D1	1,343 mm	2,457 mm
D2	1,469 mm	2,457 mm
E	3,441 mm	3,831 mm

The hydraulically adjustable cab allows the driver, that he can choose his field of view freely and at any time within the stroke.

LH 60 M HR – Dimensions

Port

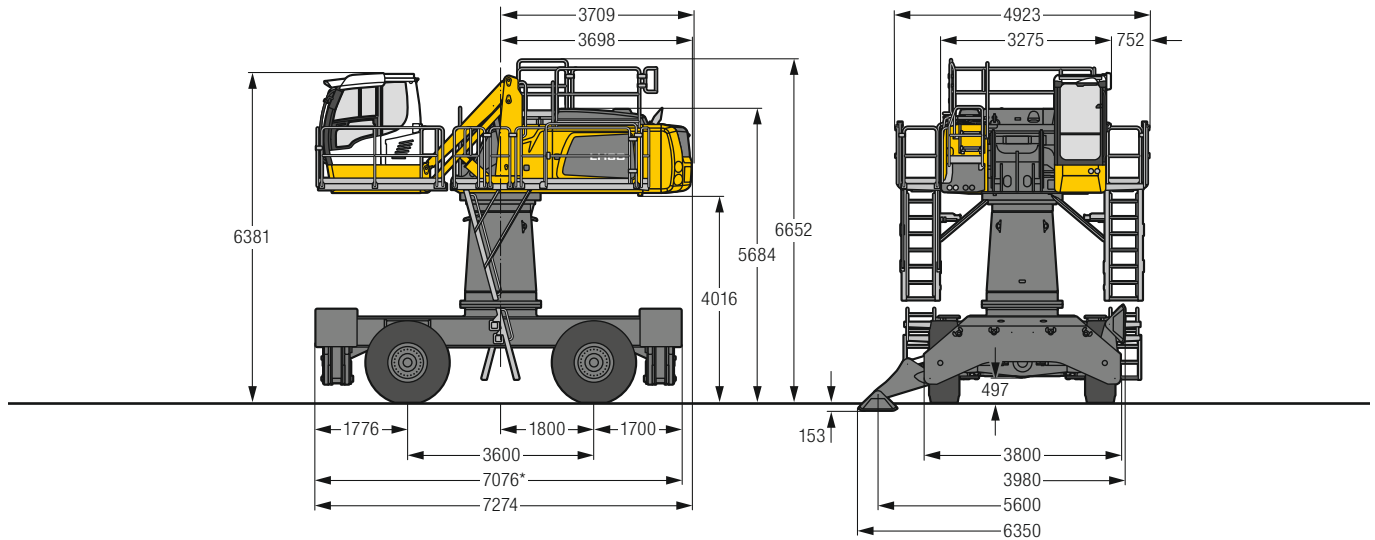

* For electric machines, the length of the machine is increased accordingly by the trailing cable / cable reel system. Detailed dimensions are available on request.

LH 60 M HR – Choice of cab elevation

Cab elevation LHC (hydraulic elevation)

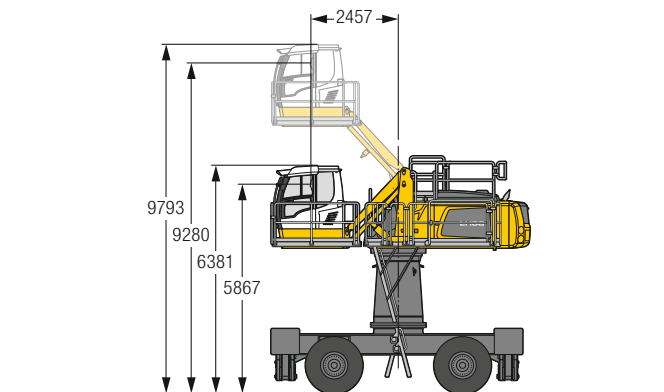

Increase type

LHC 340-35

The hydraulically adjustable cab allows the driver, that he can choose his field of view freely and at any time within the stroke.

Cab elevation LHC-D (hydraulic elevation)

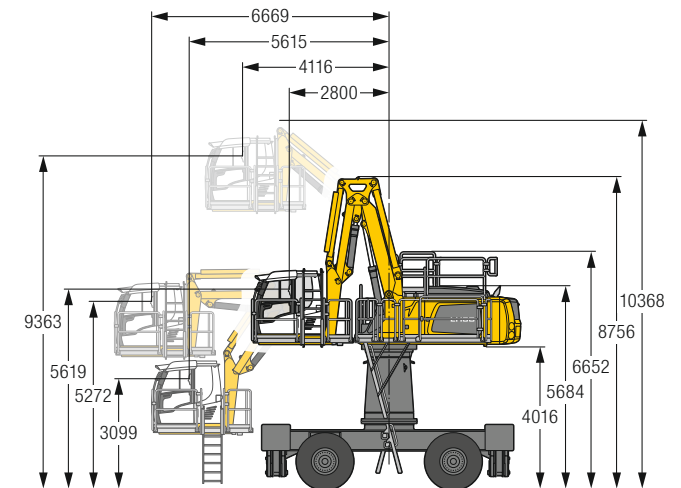

Increase type

LHC-D 730

The hydraulically adjustable cab allows the driver, that he can choose his field of view freely and at any time within the stroke.

Tyres 23.5-25

LH 60 C HR – Dimensions

Port

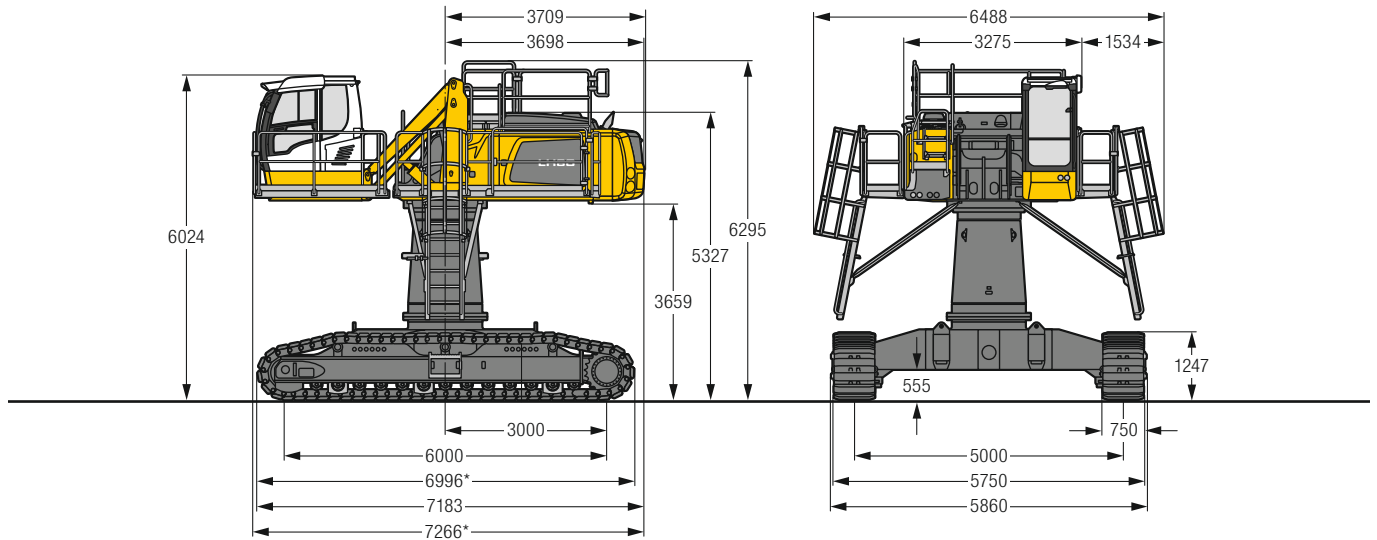

* For electric machines, the length of the machine is increased accordingly by the trailing cable / cable reel system. Detailed dimensions are available on request.

LH 60 C HR – Choice of cab elevation

Cab elevation LHC (hydraulic elevation)

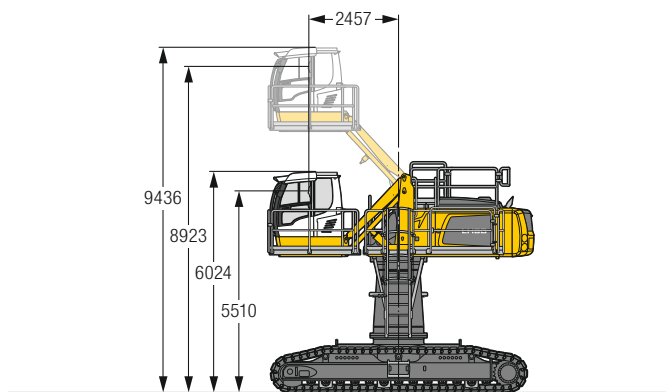

Increase type

LHC 340-35

The hydraulically adjustable cab allows the driver, that he can choose his field of view freely and at any time within the stroke.

Cab elevation LHC-D (hydraulic elevation)

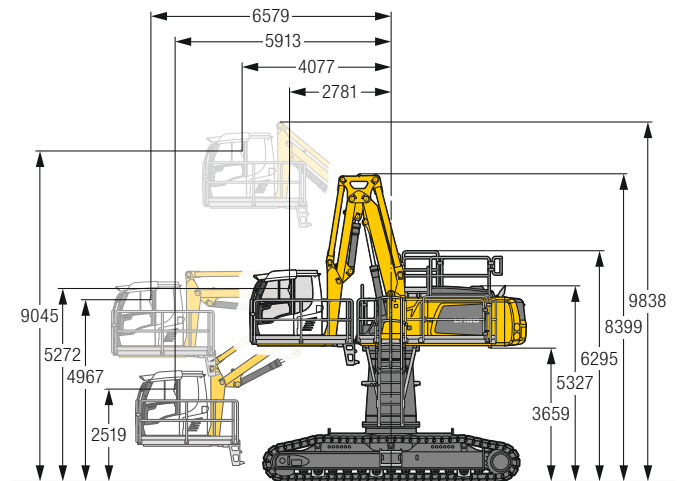

Increase type

LHC-D 730

The hydraulically adjustable cab allows the driver, that he can choose his field of view freely and at any time within the stroke.

Kinematic variant 2A

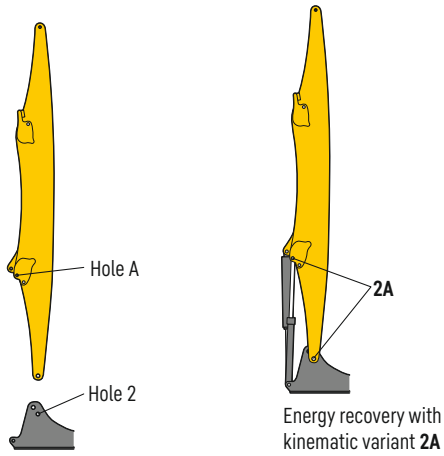

Kinematic variant 2D / 2C

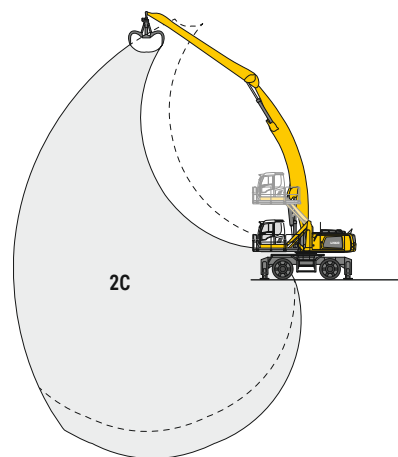
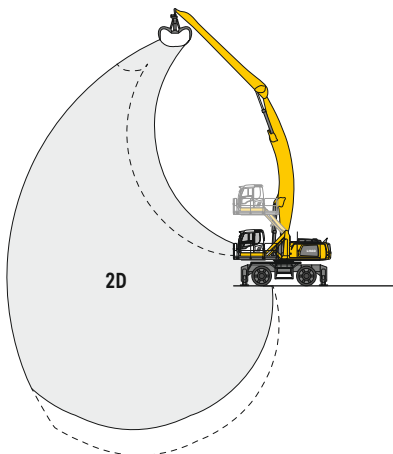
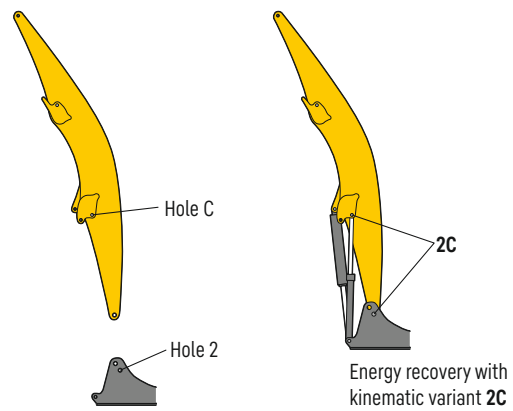
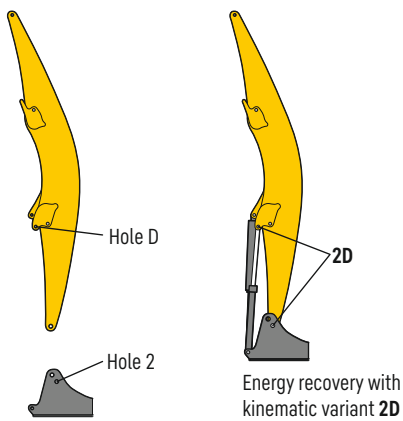

Altered range curve with additional reach depth, e.g. for unloading from ships

LH 60 M – Equipment GG16

Port – Kinematic 2A

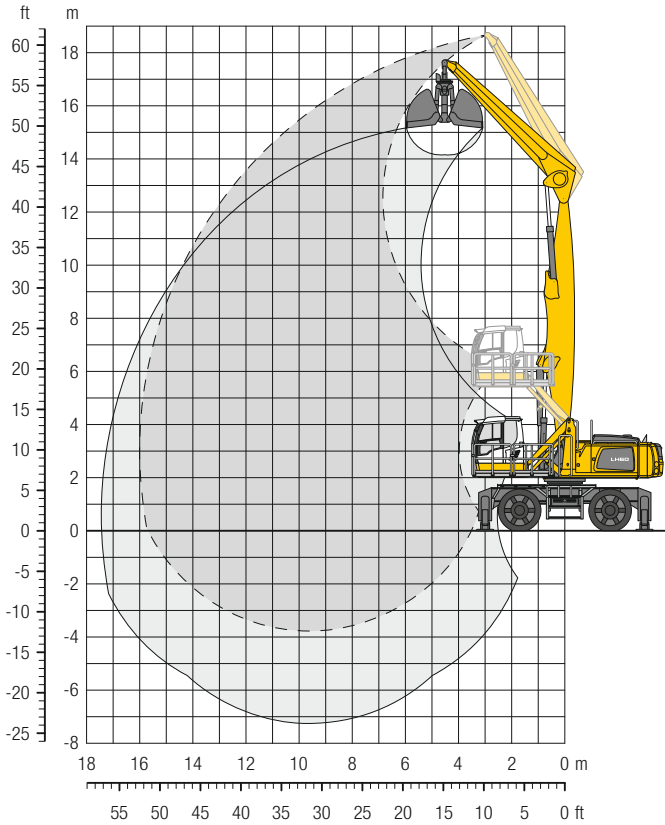

Dimensions

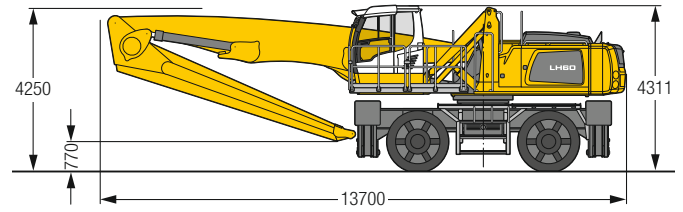

Operating weight

The operating weight includes the basic machine with 4 point outriggers, hydr. cab elevation, 4 solid tyres, straight boom 9.50 m, straight stick 6.80 m and grab for loose material GMZ 80 / 6.00 m³.

Weight 63,900 kg

m	Undercarriage	6.0 m		7.5 m		9.0 m		10.5 m		12.0 m		13.5 m		15.0 m		16.5 m		18.0 m		19.5 m		21.0 m		22.5 m		Max. reach		m
		Can be slewed through 360°	In longitudinal position of undercarriage	Can be slewed through 360°	In longitudinal position of undercarriage	Can be slewed through 360°	In longitudinal position of undercarriage	Can be slewed through 360°	In longitudinal position of undercarriage	Can be slewed through 360°	In longitudinal position of undercarriage	Can be slewed through 360°	In longitudinal position of undercarriage	Can be slewed through 360°	In longitudinal position of undercarriage	Can be slewed through 360°	In longitudinal position of undercarriage	Can be slewed through 360°	In longitudinal position of undercarriage	Can be slewed through 360°	In longitudinal position of undercarriage	Can be slewed through 360°	In longitudinal position of undercarriage	Can be slewed through 360°	In longitudinal position of undercarriage	Can be slewed through 360°	In longitudinal position of undercarriage	
18.0	4 pt. outriggers down																									15.6*	15.6*	5.4
16.5	4 pt. outriggers down	16.9*	16.9*	14.6*	14.6*																					11.9*	11.9*	8.5
15.0	4 pt. outriggers down			16.1*	16.1*	14.4*	14.4*	10.6*	10.6*																	10.4*	10.4*	10.6
13.5	4 pt. outriggers down			15.7*	15.7*	14.1*	14.1*	12.9*	12.9*	9.8*	9.8*															9.5*	9.5*	12.1
12.0	4 pt. outriggers down			15.6*	15.6*	14.0*	14.0*	12.8*	12.8*	11.8*	11.8*															9.0*	9.0*	13.2
10.5	4 pt. outriggers down			15.8*	15.8*	14.1*	14.1*	12.8*	12.8*	11.8*	11.8*	10.9*	10.9*													8.7*	8.7*	14.1
9.0	4 pt. outriggers down	17.5*	17.5*	16.4*	16.4*	14.5*	14.5*	13.0*	13.0*	11.9*	11.9*	10.9*	10.9*													8.5*	8.5*	14.8
7.5	4 pt. outriggers down	19.3*	19.3*	17.2*	17.2*	15.0*	15.0*	13.3*	13.3*	12.0*	12.0*	11.0*	11.0*	9.9*	9.9*											8.4*	8.4*	15.4
6.0	4 pt. outriggers down	22.1*	22.1*	18.2*	18.2*	15.6*	15.6*	13.7*	13.7*	12.2*	12.2*	11.0*	11.0*	9.9	9.9*											8.4*	8.4*	15.7
4.5	4 pt. outriggers down	24.0*	24.0*	19.3*	19.3*	16.3*	16.3*	14.1*	14.1*	12.5*	12.5*	11.1*	11.1*	9.8	9.8*											8.5*	8.5*	15.9
3.0	4 pt. outriggers down	25.6*	25.6*	20.2*	20.2*	16.8*	16.8*	14.4*	14.4*	12.6*	12.6*	11.1*	11.1*	9.7*	9.7*											8.4*	8.4*	16.0
1.5	4 pt. outriggers down	15.8*	15.8*	20.7*	20.7*	17.1*	17.1*	14.5*	14.5*	12.5*	12.5*	10.9*	10.9*	9.3*	9.3*											7.8*	7.8*	15.9
0	4 pt. outriggers down	12.7*	12.7*	20.3*	20.3*	16.8*	16.8*	14.2*	14.2*	12.2*	12.2*	10.4*	10.4*	8.5*	8.5*											7.2*	7.2*	15.7
-1.5	4 pt. outriggers down	12.9*	12.9*	19.1*	19.1*	16.0*	16.0*	13.5*	13.5*	11.4*	11.4*	9.5*	9.5*													7.7*	7.7*	14.7
-3.0	4 pt. outriggers down			16.8*	16.8*	14.3*	14.3*	12.1*	12.1*	10.0*	10.0*															9.0*	9.0*	12.8

Height Can be slewed through 360° In longitudinal position of undercarriage Max. reach * Limited by hydr. capacity

The lift capacities on the stick end without attachment are stated in metric tons (t) and are valid on a firm, level supporting surface with blocked oscillating axle. These capacities can be slewed through 360° with the undercarriage in the transverse position. Capacities in the longitudinal position of the undercarriage (±15°) are specified over the rigid axle with the stabilizers down. Indicated loads based on the ISO 10567 standard and do not exceed 75% of tipping or 87% of hydraulic capacity. The lift capacity values indicated are attained at the corresponding operating temperature. This operating temperature is ensured by continuous movement of the boom. Weights of fitted attachments (grabs, load hooks, etc.) and load accommodation attachment are to be deducted from the lift capacity values. The lift capacity of the unit is limited by its stability, the lifting capability of the hydraulic elements, or the maximum permissible lifting capacity of the load hook. In accordance with the harmonised European Standard EN 474-5, hydraulic excavators used for lifting operations must be equipped with pipe fracture safety valves, an overload warning device, a load hook and a lift capacity chart.

LH 60 M – Equipment GG21

Port – Kinematic 2A

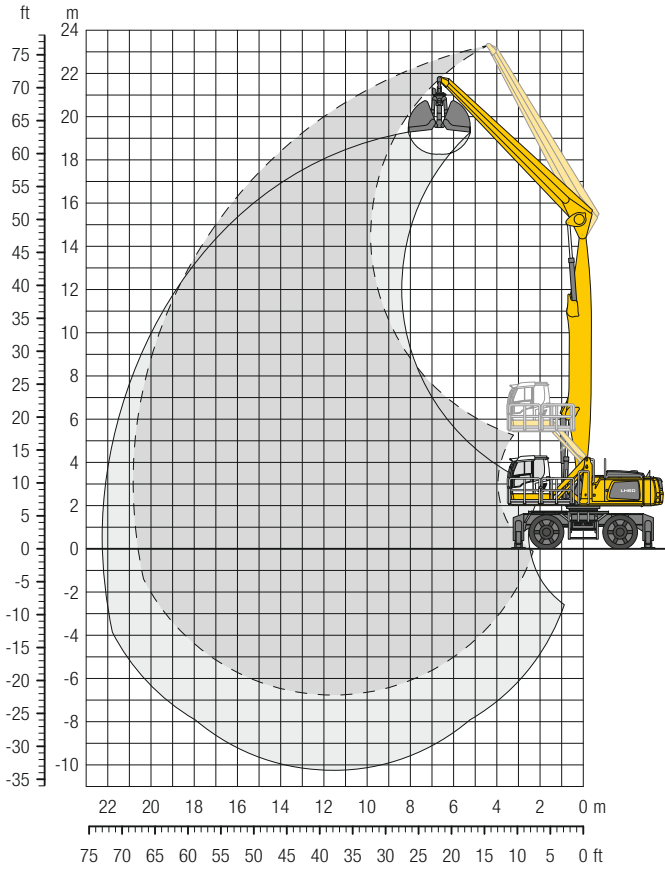

Dimensions

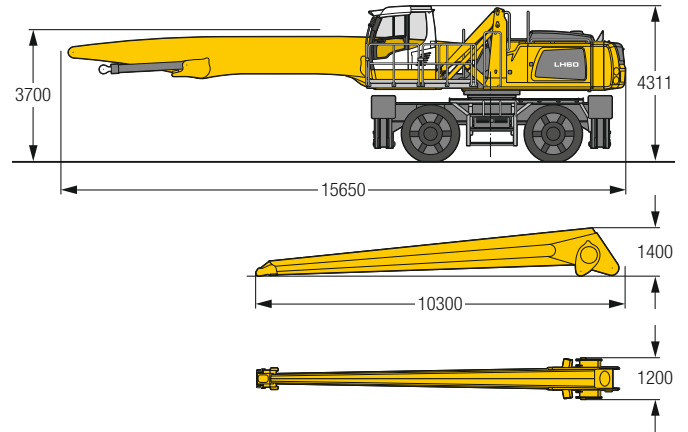

Operating weight

The operating weight includes the basic machine with 4 point outriggers, hydr. cab elevation, 4 solid tyres, straight boom 11,50 m, straight stick 9,80 m and grab for loose material GMZ 80 / 4,00 m³.

Weight 64.800 kg

m	Undercarriage	6.0 m		7.5 m		9.0 m		10.5 m		12.0 m		13.5 m		15.0 m		16.5 m		18.0 m		19.5 m		21.0 m		22.5 m		m		
		Can be slewed through 360°	In longitudinal position of undercarriage	Can be slewed through 360°	In longitudinal position of undercarriage	Can be slewed through 360°	In longitudinal position of undercarriage	Can be slewed through 360°	In longitudinal position of undercarriage	Can be slewed through 360°	In longitudinal position of undercarriage	Can be slewed through 360°	In longitudinal position of undercarriage	Can be slewed through 360°	In longitudinal position of undercarriage	Can be slewed through 360°	In longitudinal position of undercarriage	Can be slewed through 360°	In longitudinal position of undercarriage	Can be slewed through 360°	In longitudinal position of undercarriage	Can be slewed through 360°	In longitudinal position of undercarriage	Can be slewed through 360°	In longitudinal position of undercarriage	Can be slewed through 360°	In longitudinal position of undercarriage	Max. reach
22.5	4 pt. outriggers down	12.1*	12.1*																							10.5*	10.5*	7.1
21.0	4 pt. outriggers down			11.6*	11.6*																					8.3*	8.3*	10.4
19.5	4 pt. outriggers down					10.2*	10.2*																			7.3*	7.3*	12.7
18.0	4 pt. outriggers down							10.1*	10.1*	8.4*	8.4*															6.7*	6.7*	14.4
16.5	4 pt. outriggers down							10.7*	10.7*	9.8*	9.8*	8.3*	8.3*	7.8*	7.8*											6.2*	6.2*	15.8
15.0	4 pt. outriggers down							10.6*	10.6*	9.7*	9.7*	8.9*	8.9*	8.3*	8.3*	7.1*	7.1*									6.0*	6.0*	17.0
13.5	4 pt. outriggers down							10.6*	10.6*	9.7*	9.7*	8.9*	8.9*	8.3*	8.3*	7.7*	7.7*									5.8*	5.8*	18.0
12.0	4 pt. outriggers down							10.7*	10.7*	9.7*	9.7*	8.9*	8.9*	8.3*	8.3*	7.2*	7.2*	7.2*	7.2*							5.6*	5.6*	18.8
10.5	4 pt. outriggers down					11.9*	11.9*	10.9*	10.9*	9.9*	9.9*	9.0*	9.0*	8.3*	8.3*	7.7*	7.7*	7.2*	7.2*							5.5*	5.5*	19.4
9.0	4 pt. outriggers down					12.4*	12.4*	11.1*	11.1*	10.0*	10.0*	9.2*	9.2*	8.4*	8.4*	7.8*	7.8*	7.2*	7.2*	6.5	6.6*					5.5*	5.5*	19.9
7.5	4 pt. outriggers down			12.1*	12.1*	13.0*	13.0*	11.5*	11.5*	10.3*	10.3*	9.3*	9.3*	8.5*	8.5*	7.8*	7.8*	7.2*	7.2*	6.4	6.6*					5.5*	5.5*	20.3
6.0	4 pt. outriggers down	12.1*	12.1*	14.8*	14.8*	13.6*	13.6*	11.9*	11.9*	10.6*	10.6*	9.5*	9.5*	8.6*	8.6*	7.9*	7.9*	7.2*	7.2*	6.3	6.6*					5.5*	5.5*	20.6
4.5	4 pt. outriggers down	21.1*	21.1*	17.0*	17.0*	14.2*	14.2*	12.3*	12.3*	10.8*	10.8*	9.7*	9.7*	8.7*	8.7*	7.9*	7.9*	7.2*	7.2*	6.3	6.5*					5.6*	5.6*	20.8
3.0	4 pt. outriggers down	22.5*	22.5*	17.8*	17.8*	14.8*	14.8*	12.6*	12.6*	11.1*	11.1*	9.8*	9.8*	8.8*	8.8*	7.9*	7.9*	7.0	7.2*	6.2	6.4*					5.4*	5.4*	20.8
1.5	4 pt. outriggers down	11.6*	11.6*	18.4*	18.4*	15.2*	15.2*	12.9*	12.9*	11.2*	11.2*	9.9*	9.9*	8.8*	8.8*	7.9*	7.9*	6.9	7.1*	6.1	6.2*					5.1*	5.1*	20.8
0	4 pt. outriggers down	7.6*	7.6*	18.6*	18.6*	15.3*	15.3*	13.0*	13.0*	11.2*	11.2*	9.9*	9.9*	8.7*	8.7*	7.7	7.8*	6.8	6.8*	5.8*	5.8*					4.8*	4.8*	20.6
-1.5	4 pt. outriggers down	7.0*	7.0*	14.2*	14.2*	15.1*	15.1*	12.8*	12.8*	11.1*	11.1*	9.7*	9.7*	8.5*	8.5*	7.5*	7.5*	6.5*	6.5*	5.3*	5.3*					4.4*	4.4*	20.3
-3.0	4 pt. outriggers down	7.4*	7.4*	12.8*	12.8*	14.5*	14.5*	12.4*	12.4*	10.7*	10.7*	9.3*	9.3*	8.1*	8.1*	7.0*	7.0*	5.9*	5.9*							4.6*	4.6*	19.3
-4.5	4 pt. outriggers down	8.1*	8.1*	12.8*	12.8*	13.3*	13.3*	11.5*	11.5*	9.9*	9.9*	8.6*	8.6*	7.4*	7.4*	6.3*	6.3*									5.1*	5.1*	17.9
-6.0	4 pt. outriggers down					11.6*	11.6*	10.1*	10.1*	8.8*	8.8*	7.6*	7.6*	6.4*	6.4*											6.0*	6.0*	15.4

Height Can be slewed through 360° In longitudinal position of undercarriage Max. reach * Limited by hydr. capacity

The lift capacities on the stick end without attachment are stated in metric tons (t) and are valid on a firm, level supporting surface with blocked oscillating axle. These capacities can be slewed through 360° with the undercarriage in the transverse position. Capacities in the longitudinal position of the undercarriage (±15°) are specified over the rigid axle with the stabilizers down. Indicated loads based on the ISO 10567 standard and do not exceed 75% of tipping or 87% of hydraulic capacity. The lift capacity values indicated are attained at the corresponding operating temperature. This operating temperature is ensured by continuous movement of the boom. Weights of fitted attachments (grabs, load hooks, etc.) and load accommodation attachment are to be deducted from the lift capacity values. The lift capacity of the unit is limited by its stability, the lifting capability of the hydraulic elements, or the maximum permissible lifting capacity of the load hook. In accordance with the harmonised European Standard EN 474-5, hydraulic excavators used for lifting operations must be equipped with pipe fracture safety valves, an overload warning device, a load hook and a lift capacity chart.

LH 60 M – Equipment AG20

Port – Kinematic 2D

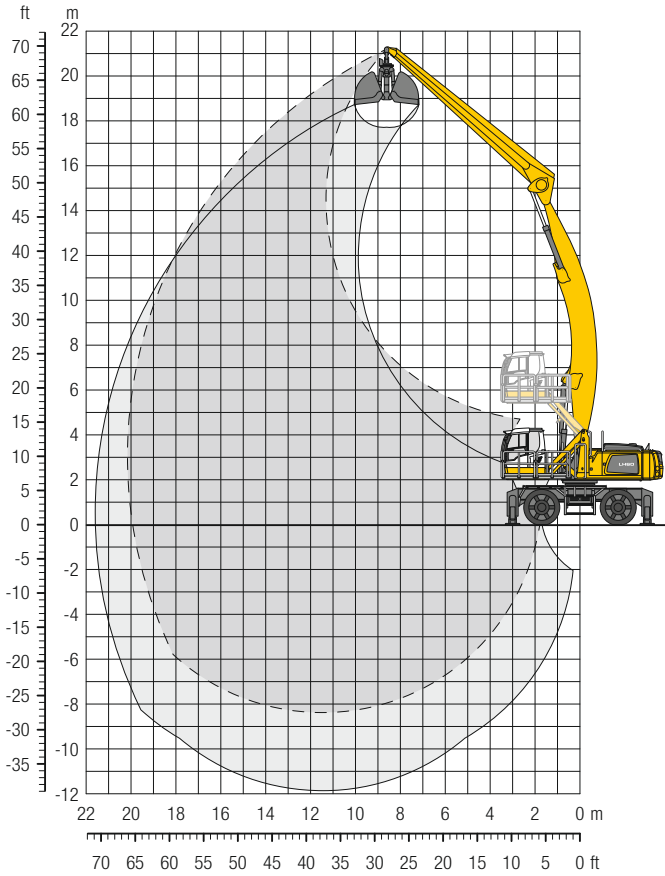

Dimensions

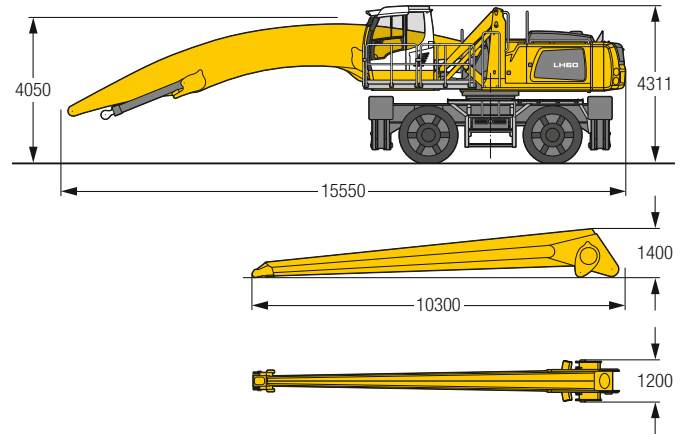

Operating weight

The operating weight includes the basic machine with 4 point outriggers, hydr. cab elevation, 4 solid tyres, angled boom 11.50 m, straight stick 9.80 m and grab for loose material GMZ 80 / 4.00 m³.

Weight 65,300 kg

m	Undercarriage	6.0 m		7.5 m		9.0 m		10.5 m		12.0 m		13.5 m		15.0 m		16.5 m		18.0 m		19.5 m		21.0 m		22.5 m		Grab		m		
		Left	Right	Left	Right	Left	Right	Left	Right	Left	Right	Left	Right	Left	Right	Left	Right	Left	Right	Left	Right	Left	Right	Left	Right	Left	Right			
21.0	4 pt. outriggers down																											7.8*	7.8*	9.0
19.5	4 pt. outriggers down							8.1*	8.1*																			6.8*	6.8*	11.5
18.0	4 pt. outriggers down									8.1*	8.1*																	6.3*	6.3*	13.4
16.5	4 pt. outriggers down									8.4*	8.4*	7.9*	7.9*															6.0*	6.0*	15.0
15.0	4 pt. outriggers down									8.3*	8.3*	7.8*	7.8*	7.3*	7.3*													5.7*	5.7*	16.2
13.5	4 pt. outriggers down									8.3*	8.3*	7.7*	7.7*	7.3*	7.3*	6.8*	6.8*											5.6*	5.6*	17.2
12.0	4 pt. outriggers down									8.4*	8.4*	7.8*	7.8*	7.3*	7.3*	6.9*	6.9*	5.6*	5.6*									5.5*	5.5*	18.0
10.5	4 pt. outriggers down							9.3*	9.3*	8.5*	8.5*	7.9*	7.9*	7.4*	7.4*	6.9*	6.9*	6.6*	6.6*									5.5*	5.5*	18.7
9.0	4 pt. outriggers down							9.6*	9.6*	8.7*	8.7*	8.0*	8.0*	7.5*	7.5*	7.0*	7.0*	6.6*	6.6*									5.5*	5.5*	19.3
7.5	4 pt. outriggers down					11.2*	11.2*	10.0*	10.0*	9.0*	9.0*	8.2*	8.2*	7.6*	7.6*	7.1*	7.1*	6.6*	6.6*	5.9*	5.9*							5.5*	5.5*	19.7
6.0	4 pt. outriggers down			13.8*	13.8*	11.9*	11.9*	10.4*	10.4*	9.3*	9.3*	8.5*	8.5*	7.8*	7.8*	7.2*	7.2*	6.7*	6.7*	6.3*	6.3*							5.6*	5.6*	19.9
4.5	4 pt. outriggers down	18.4*	18.4*	14.9*	14.9*	12.6*	12.6*	10.9*	10.9*	9.7*	9.7*	8.7*	8.7*	8.0*	8.0*	7.3*	7.3*	6.8*	6.8*	6.3*	6.3*							5.7*	5.7*	20.1
3.0	4 pt. outriggers down	20.2*	20.2*	16.0*	16.0*	13.3*	13.3*	11.4*	11.4*	10.0*	10.0*	9.0*	9.0*	8.1*	8.1*	7.4*	7.4*	6.8*	6.8*	6.2	6.3*							5.8	5.9*	20.2
1.5	4 pt. outriggers down	17.5*	17.5*	16.9*	16.9*	13.9*	13.9*	11.9*	11.9*	10.4*	10.4*	9.2*	9.2*	8.3*	8.3*	7.5*	7.5*	6.9*	6.9*	6.1	6.3*							5.8	6.0*	20.1
0	4 pt. outriggers down	10.9*	10.9*	17.6*	17.6*	14.4*	14.4*	12.2*	12.2*	10.6*	10.6*	9.4*	9.4*	8.4*	8.4*	7.6*	7.6*	6.8	6.9*	6.0	6.1*							5.8	5.9*	19.9
-0.5	4 pt. outriggers down	9.4*	9.4*	17.2*	17.2*	14.7*	14.7*	12.4*	12.4*	10.7*	10.7*	9.5*	9.5*	8.4*	8.4*	7.5*	7.5*	6.7	6.8*	5.9*	5.9*							5.8*	5.8*	19.7
-3.0	4 pt. outriggers down	9.2*	9.2*	14.9*	14.9*	14.6*	14.6*	12.4*	12.4*	10.7*	10.7*	9.4*	9.4*	8.3*	8.3*	7.4*	7.4*	6.5*	6.5*									5.7*	5.7*	19.2
-4.5	4 pt. outriggers down	9.5*	9.5*	14.2*	14.2*	14.2*	14.2*	12.1*	12.1*	10.5*	10.5*	9.2*	9.2*	8.1*	8.1*	7.1*	7.1*	6.1*	6.1*									5.5*	5.5*	18.7
-6.0	4 pt. outriggers down	10.0*	10.0*	14.2*	14.2*	13.4*	13.4*	11.5*	11.5*	10.0*	10.0*	8.7*	8.7*	7.6*	7.6*	6.5*	6.5*											5.3*	5.3*	17.9
-7.5	4 pt. outriggers down			14.1*	14.1*	12.2*	12.2*	10.5*	10.5*	9.1*	9.1*	7.9*	7.9*	6.7*	6.7*													6.3*	6.3*	15.6

Height Can be slewed through 360° In longitudinal position of undercarriage Max. reach * Limited by hydr. capacity

The lift capacities on the stick end without attachment are stated in metric tons (t) and are valid on a firm, level supporting surface with blocked oscillating axle. These capacities can be slewed through 360° with the undercarriage in the transverse position. Capacities in the longitudinal position of the undercarriage (±15°) are specified over the rigid axle with the stabilizers down. Indicated loads based on the ISO 10567 standard and do not exceed 75% of tipping or 87% of hydraulic capacity. The lift capacity values indicated are attained at the corresponding operating temperature. This operating temperature is ensured by continuous movement of the boom. Weights of fitted attachments (grabs, load hooks, etc.) and load accommodation attachment are to be deducted from the lift capacity values. The lift capacity of the unit is limited by its stability, the lifting capability of the hydraulic elements, or the maximum permissible lifting capacity of the load hook. In accordance with the harmonised European Standard EN 474-5, hydraulic excavators used for lifting operations must be equipped with pipe fracture safety valves, an overload warning device, a load hook and a lift capacity chart.

LH 60 C – Equipment GG19

Port – Kinematic 2A

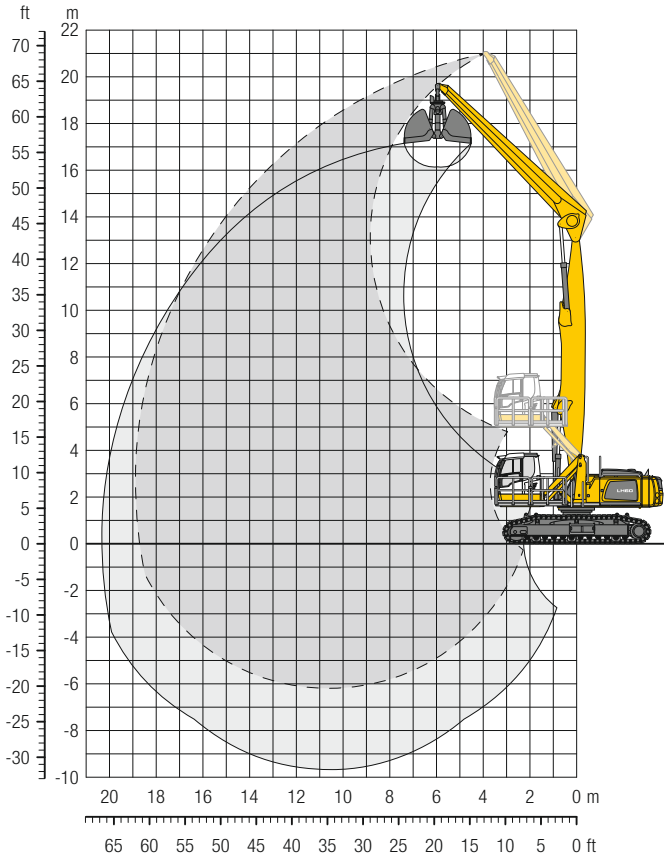

Dimensions

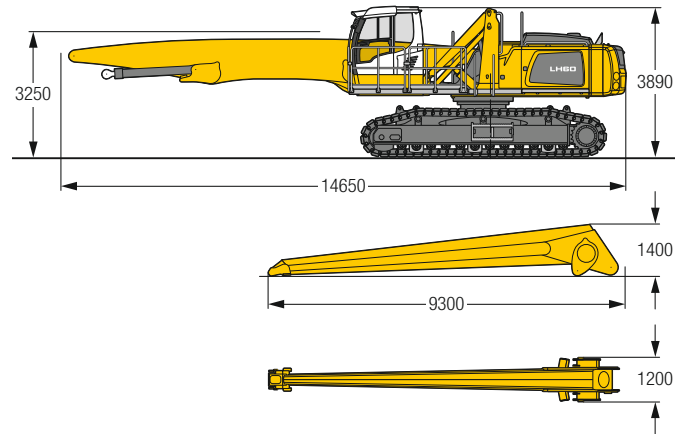

Operating weight and ground pressure

The operating weight includes the basic machine with hydr. cab elevation, straight boom 10.50 m, straight stick 8.80 m and grab for loose material GMZ 80 / 4.00 m³.

Weight	66,000 kg
Pad width	750 mm
Ground pressure	on request

m	Undercarriage	6.0 m		7.5 m		9.0 m		10.5 m		12.0 m		13.5 m		15.0 m		16.5 m		18.0 m		19.5 m		21.0 m		22.5 m		Grab		m
		SW	SW	SW	SW	SW	SW	SW	SW	SW	SW	SW	SW	SW	SW	SW	SW	SW	SW	SW	SW	SW	SW	SW	SW	SW	SW	
19.5	SW			11.6*	11.6*																					10.3*	10.3*	8.2
18.0	SW			12.9*	12.9*																					8.6*	8.6*	10.8
16.5	SW					11.5*	11.5*	9.3*	9.3*																	7.7*	7.7*	12.7
15.0	SW					12.4*	12.4*	11.2*	11.2*	9.3*	9.3*															7.2*	7.2*	14.2
13.5	SW					12.3*	12.3*	11.2*	11.2*	10.4*	10.4*	9.7*	9.7*	7.9*	7.9*											6.8*	6.8*	15.4
12.0	SW					12.4*	12.4*	11.2*	11.2*	10.3*	10.3*	9.6*	9.6*	8.5	9.0*											6.5*	6.5*	16.3
10.5	SW					12.5*	12.5*	11.4*	11.4*	10.4*	10.4*	9.6*	9.6*	8.5	9.0*	7.2	8.2*									6.4*	6.4*	17.1
9.0	SW					12.9*	12.9*	11.6*	11.6*	10.6*	10.6*	9.7*	9.7*	8.5	9.0*	7.1	8.4*									6.2	6.3*	17.8
7.5	SW			13.8*	13.8*	13.4*	13.4*	12.0*	12.0*	10.8*	10.8*	9.9*	9.9*	8.3	9.1*	7.1	8.4*	6.0	7.1*							5.9	6.2*	18.2
6.0	SW	13.4*	13.4*	16.0*	16.0*	14.0*	14.0*	12.4*	12.4*	11.1*	11.1*	9.7	10.1*	8.2	9.2*	7.0	8.4*	6.0	7.5							5.7	6.3*	18.6
4.5	SW	19.8*	19.8*	17.3*	17.3*	14.7*	14.7*	12.8*	12.8*	11.3	11.4*	9.4	10.2*	8.0	9.3*	6.9	8.4*	5.9	7.5							5.5	6.3*	18.8
3.0	SW	23.1*	23.1*	18.4*	18.4*	15.4*	15.4*	13.3*	13.3*	10.9	11.7*	9.2	10.4*	7.8	9.4*	6.7	8.4*	5.9	7.4							5.4	6.4*	18.9
1.5	SW	24.2*	24.2*	19.2*	19.2*	15.9*	15.9*	12.8	13.6*	10.5	11.9*	8.9	10.5*	7.6	9.3*	6.6	8.3*	5.8	7.2*							5.4	6.3*	18.9
0	SW	11.6*	11.6*	19.6*	19.6*	15.2	16.2*	12.3	13.7*	10.2	11.9*	8.7	10.5*	7.5	9.2*	6.5	8.1*	5.7	6.8*							5.4	5.9*	18.7
-1.5	SW	9.8*	9.8*	19.0	19.4*	14.7	16.1*	11.9	13.6*	9.9	11.7*	8.5	10.2*	7.3	8.9*	6.4	7.6*	5.7	6.1*							5.5*	5.5*	18.4
-3.0	SW	9.9*	9.9*	18.4*	18.4*	14.4	15.4*	11.6	13.1*	9.7	11.3*	8.3	9.7*	7.2	8.3*	6.4	6.9*									5.8*	5.8*	17.4
-4.5	SW	10.7*	10.7*	16.7*	16.7*	14.2	14.2*	11.5	12.1*	9.6	10.4*	8.2	8.8*	7.2	7.4*											6.5*	6.5*	15.8
-6.0	SW					12.2*	12.2*	10.5*	10.5*	8.9*	8.9*															8.3*	8.3*	12.6

Height Can be slewed through 360° In longitudinal position of undercarriage Max. reach * Limited by hydr. capacity

The lift capacities on the stick end without attachment are stated in metric tons (t) and can be slewed through 360° on a firm, level supporting surface. Capacities are valid for 750 mm wide triple grouser pads (resp. flat pads). Indicated loads based on the ISO 10567 standard and do not exceed 75% of tipping or 87% of hydraulic capacity. The lift capacity values indicated are attained at the corresponding operating temperature. This operating temperature is ensured by continuous movement of the boom. Weights of fitted attachments (grabs, load hooks, etc.) and load accommodation attachment are to be deducted from the lift capacity values. The lift capacity of the unit is limited by its stability, the lifting capability of the hydraulic elements, or the maximum permissible lifting capacity of the load hook. In accordance with the harmonised European Standard EN 474-5, hydraulic excavators used for lifting operations must be equipped with pipe fracture safety valves, an overload warning device, a load hook and a lift capacity chart.

LH 60 C – Equipment AG18

Port – Kinematic 2D

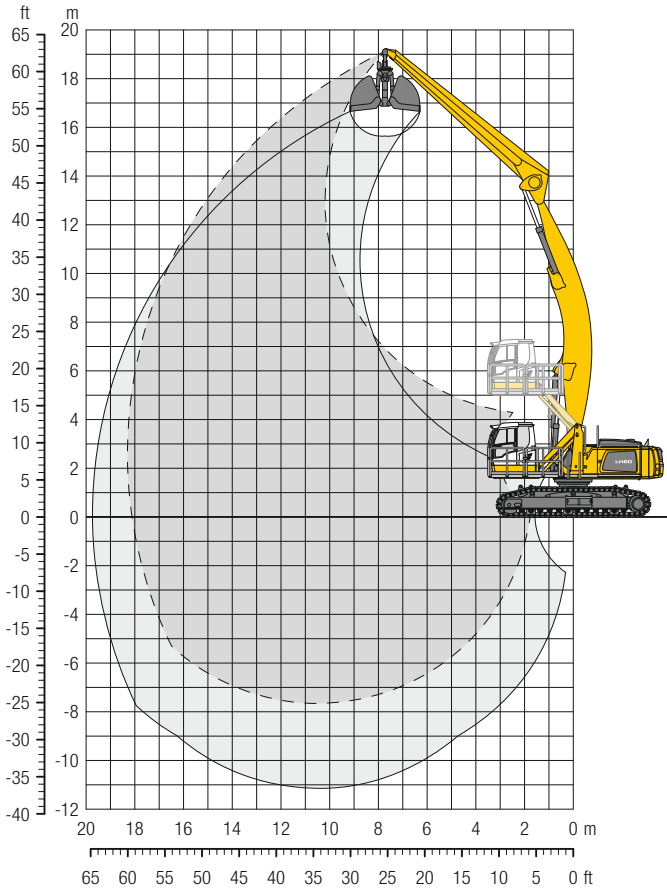

Dimensions

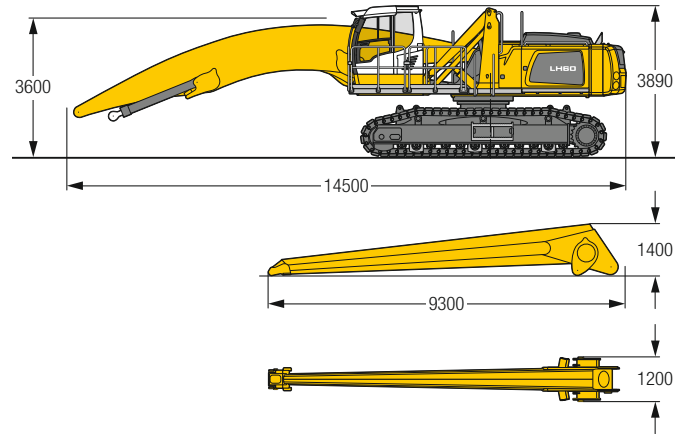

Operating weight and ground pressure

The operating weight includes the basic machine with hydr. cab elevation, angled boom 10.50 m, straight stick 8.80 m and grab for loose material GMZ 80 / 4.00 m³.

Weight	66,500 kg
Pad width	750 mm
Ground pressure	on request

m	Undercarriage	6.0 m		7.5 m		9.0 m		10.5 m		12.0 m		13.5 m		15.0 m		16.5 m		18.0 m		19.5 m		21.0 m		22.5 m		Max. reach		m	
		SW	SW	SW	SW	SW	SW	SW	SW	SW	SW	SW	SW	SW	SW	SW	SW	SW	SW	SW	SW	SW	SW	SW	SW	SW	SW		SW
18.0	SW			9.2*	9.2*																					8.1*	8.1*	9.7	
16.5	SW							9.3*	9.3*																				11.8
15.0	SW							9.8*	9.8*	9.1*	9.1*																		13.4
13.5	SW							9.6*	9.6*	9.0*	9.0*	8.6*	8.6*																14.6
12.0	SW							9.6*	9.6*	9.0*	9.0*	8.5*	8.5*	7.8*	7.8*														15.7
10.5	SW							9.8*	9.8*	9.1*	9.1*	8.5*	8.5*	8.1*	8.1*														16.5
9.0	SW							10.0*	10.0*	9.3*	9.3*	8.6*	8.6*	8.1*	8.1*	7.2	7.7*												17.1
7.5	SW					11.5*	11.5*	10.4*	10.4*	9.5*	9.5*	8.8*	8.8*	8.2*	8.2*	7.1	7.7*												17.6
6.0	SW			14.0*	14.0*	12.2*	12.2*	10.9*	10.9*	9.9*	9.9*	9.1*	9.1*	8.3	8.4*	7.0	7.8*												18.0
4.5	SW	18.5*	18.5*	15.2*	15.2*	13.0*	13.0*	11.4*	11.4*	10.2*	10.2*	9.3*	9.3*	8.1	8.6*	6.9	7.9*	5.9	7.1*										18.2
3.0	SW	20.6*	20.6*	16.5*	16.5*	13.8*	13.8*	12.0*	12.0*	10.6*	10.6*	9.3	9.6*	7.9	8.7*	6.7	8.0*	5.8	7.4										18.3
1.5	SW	22.4*	22.4*	17.6*	17.6*	14.6*	14.6*	12.5*	12.5*	10.6	11.0*	8.9	9.8*	7.6	8.9*	6.6	8.1*	5.7	7.3										18.3
0	SW	15.9*	15.9*	18.5*	18.5*	15.2*	15.2*	12.3	12.9*	10.2	11.3*	8.7	10.0*	7.4	9.0*	6.4	8.1*	5.7	7.2										18.1
-1.5	SW	12.6*	12.6*	18.9*	18.9*	14.7	15.5*	11.9	13.2*	9.9	11.4*	8.4	10.1*	7.3	9.0*	6.3	8.0*												17.8
-3.0	SW	11.9*	11.9*	18.4	18.8*	14.2	15.5*	11.6	13.2*	9.6	11.4*	8.2	10.0*	7.1	8.8*	6.3	7.7*												17.4
-4.5	SW	12.1*	12.1*	18.1	18.1*	14.0	15.1*	11.3	12.9*	9.5	11.1*	8.1	9.6*	7.0	8.4*	6.2	7.0*												16.9
-6.0	SW	12.7*	12.7*	16.8*	16.8*	13.8	14.2*	11.2	12.1*	9.4	10.4*	8.0	8.9*	7.0	8.5*														15.7
-7.5	SW			12.6*	12.6*	10.8*	10.8*	9.2*	9.2*																				12.4

Height Can be slewed through 360° In longitudinal position of undercarriage Max. reach * Limited by hydr. capacity

The lift capacities on the stick end without attachment are stated in metric tons (t) and can be slewed through 360° on a firm, level supporting surface. Capacities are valid for 750 mm wide triple grouser pads (resp. flat pads). Indicated loads based on the ISO 10567 standard and do not exceed 75% of tipping or 87% of hydraulic capacity. The lift capacity values indicated are attained at the corresponding operating temperature. This operating temperature is ensured by continuous movement of the boom. Weights of fitted attachments (grabs, load hooks, etc.) and load accommodation attachment are to be deducted from the lift capacity values. The lift capacity of the unit is limited by its stability, the lifting capability of the hydraulic elements, or the maximum permissible lifting capacity of the load hook. In accordance with the harmonised European Standard EN 474-5, hydraulic excavators used for lifting operations must be equipped with pipe fracture safety valves, an overload warning device, a load hook and a lift capacity chart.

LH 60 M HR – Equipment GG24

Port – Kinematic 2A

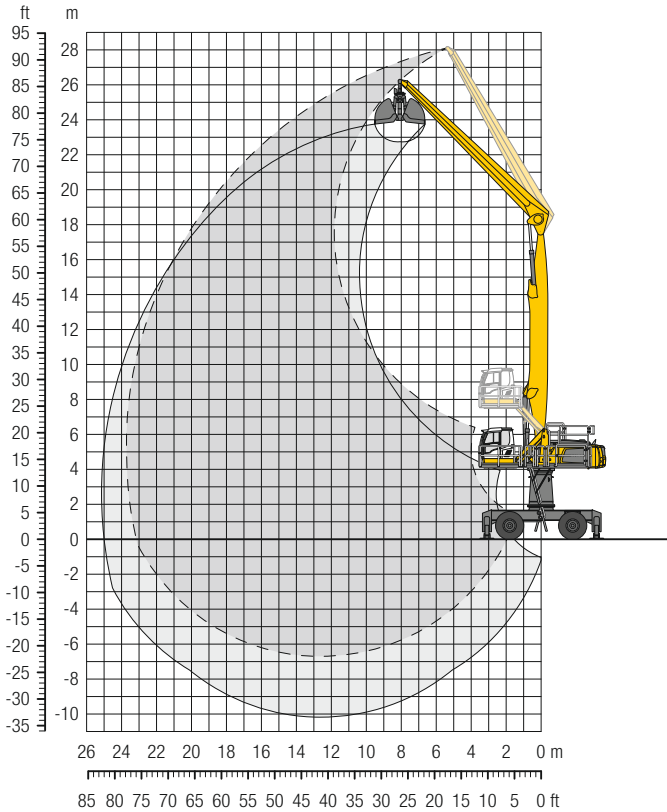

Dimensions

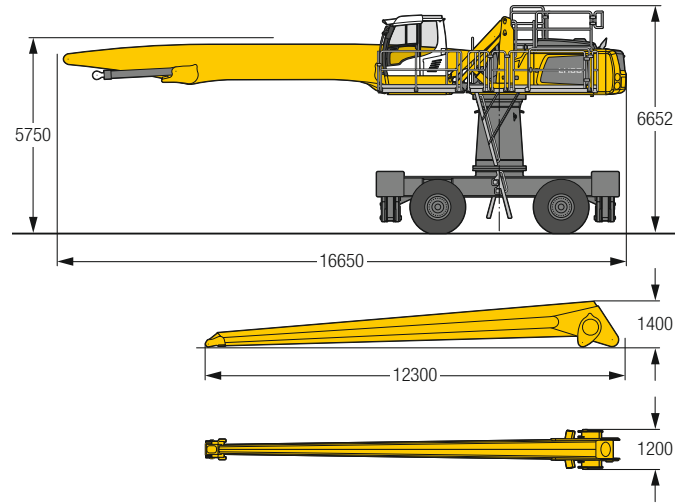

Operating weight

The operating weight includes the basic machine with 4 point outriggers, turret 2,000 mm, hydr. cab elevation, 4 solid tyres, straight boom 12.50 m, straight stick 11.80 m and grab for loose material GMZ 80 / 3.50 m³.

Weight 75,600 kg

m	Undercarriage	6.0 m		7.5 m		9.0 m		10.5 m		12.0 m		13.5 m		15.0 m		16.5 m		18.0 m		19.5 m		21.0 m		22.5 m		m				
		Outrigger	Outrigger	Outrigger	Outrigger	Outrigger	Outrigger	Outrigger	Outrigger	Outrigger	Outrigger	Outrigger	Outrigger	Outrigger	Outrigger	Outrigger	Outrigger	Outrigger	Outrigger	Outrigger	Outrigger	Outrigger	Outrigger	Outrigger	Outrigger	Outrigger	Outrigger	Outrigger		
27.0	4 pt. outriggers down			9.6*	9.6*																					8.1*	8.1*	9.0		
25.5	4 pt. outriggers down					9.3*	9.3*	8.3*	8.3*	6.7*	6.7*															5.9*	5.9*	12.0		
24.0	4 pt. outriggers down							9.0*	9.0*	8.1*	8.1*	6.9*	6.9*													5.4*	5.4*	14.3		
22.5	4 pt. outriggers down									8.7*	8.7*	7.9*	7.9*	6.8*	6.8*												5.1*	5.1*	16.1	
21.0	4 pt. outriggers down									9.0*	9.0*	8.3*	8.3*	7.6*	7.6*	6.5*	6.5*										4.8*	4.8*	17.6	
19.5	4 pt. outriggers down									8.9*	8.9*	8.2*	8.2*	7.6*	7.6*	7.0*	7.0*	6.0*	6.0*								4.6*	4.6*	18.8	
18.0	4 pt. outriggers down									8.8*	8.8*	8.1*	8.1*	7.5*	7.5*	7.0*	7.0*	6.5*	6.5*	5.3*	5.3*						4.5*	4.5*	19.9	
16.5	4 pt. outriggers down									8.9*	8.9*	8.1*	8.1*	7.5*	7.5*	7.0*	7.0*	6.5*	6.5*	6.1*	6.1*						4.4*	4.4*	20.8	
15.0	4 pt. outriggers down									8.9*	8.9*	8.2*	8.2*	7.5*	7.5*	7.0*	7.0*	6.5*	6.5*	6.1*	6.1*	5.4*	5.4*				4.4*	4.4*	21.5	
13.5	4 pt. outriggers down									9.0*	9.0*	8.2*	8.2*	7.6*	7.6*	7.0*	7.0*	6.5*	6.5*	6.1*	6.1*	5.7*	5.7*				4.4*	4.4*	22.2	
12.0	4 pt. outriggers down							9.7*	9.7*	9.2*	9.2*	8.4*	8.4*	7.7*	7.7*	7.1*	7.1*	6.5*	6.5*	6.1*	6.1*	5.7*	5.7*	4.7*	4.7*		4.3*	4.3*	22.7	
10.5	4 pt. outriggers down									10.2*	10.2*	9.4*	9.4*	8.5*	8.5*	7.8*	7.8*	7.1*	7.1*	6.6*	6.6*	6.1*	6.1*	5.7*	5.7*	5.2*	5.2*	4.3*	4.3*	23.1
9.0	4 pt. outriggers down					10.1*	10.1*	10.8*	10.8*	9.6*	9.6*	8.7*	8.7*	7.9*	7.9*	7.2*	7.2*	6.6*	6.6*	6.1*	6.1*	5.6*	5.6*	5.1*	5.1*	4.3*	4.3*	23.4		
7.5	4 pt. outriggers down			10.3*	10.3*	12.2*	12.2*	11.2*	11.2*	9.9*	9.9*	8.9*	8.9*	8.0*	8.0*	7.3*	7.3*	6.7*	6.7*	6.1*	6.1*	5.6*	5.6*	5.1*	5.1*	4.3*	4.3*	23.6		
6.0	4 pt. outriggers down	13.7*	13.7*	15.9*	15.9*	13.5*	13.5*	11.6*	11.6*	10.1*	10.1*	9.0*	9.0*	8.1*	8.1*	7.4*	7.4*	6.7*	6.7*	6.1*	6.1*	5.6*	5.6*	5.0*	5.0*	4.4*	4.4*	23.7		
4.5	4 pt. outriggers down	21.3*	21.3*	16.9*	16.9*	14.0*	14.0*	11.9*	11.9*	10.4*	10.4*	9.2*	9.2*	8.2*	8.2*	7.4*	7.4*	6.7*	6.7*	6.1*	6.1*	5.5*	5.5*	4.9*	4.9*	4.2*	4.2*	23.7		
3.0	4 pt. outriggers down	11.0*	11.0*	17.4*	17.4*	14.3*	14.3*	12.1*	12.1*	10.5*	10.5*	9.3*	9.3*	8.3*	8.3*	7.4*	7.4*	6.7*	6.7*	6.0*	6.0*	5.4*	5.4*	4.7*	4.7*	4.0*	4.0*	23.6		
1.5	4 pt. outriggers down	6.6*	6.6*	16.5*	16.5*	14.5*	14.5*	12.3*	12.3*	10.6*	10.6*	9.3*	9.3*	8.2*	8.2*	7.4*	7.4*	6.6*	6.6*	5.9*	5.9*	5.2*	5.2*	4.4*	4.4*	3.7*	3.7*	23.4		
0	4 pt. outriggers down	5.8*	5.8*	11.4*	11.4*	14.4*	14.4*	12.2*	12.2*	10.5*	10.5*	9.2*	9.2*	8.1*	8.1*	7.2*	7.2*	6.4*	6.4*	5.7*	5.7*	4.9*	4.9*	4.0*	4.0*	3.4*	3.4*	23.1		
-1.5	4 pt. outriggers down	5.9*	5.9*	10.0*	10.0*	13.9*	13.9*	11.9*	11.9*	10.2*	10.2*	9.0*	9.0*	7.9*	7.9*	7.0*	7.0*	6.1*	6.1*	5.3*	5.3*	4.5*	4.5*			3.4*	3.4*	22.4		
-3.0	4 pt. outriggers down	6.4*	6.4*	9.8*	9.8*	13.1*	13.1*	11.2*	11.2*	9.8*	9.8*	8.5*	8.5*	7.5*	7.5*	6.5*	6.5*	5.7*	5.7*	4.8*	4.8*	3.8*	3.8*			3.7*	3.7*	21.2		
-4.5	4 pt. outriggers down	7.0*	7.0*	10.0*	10.0*	11.8*	11.8*	10.3*	10.3*	9.0*	9.0*	7.8*	7.8*	6.8*	6.8*	5.9*	5.9*	5.0*	5.0*							4.1*	4.1*	19.4		
-6.0	4 pt. outriggers down			10.1*	10.1*	8.9*	8.9*	7.8*	7.8*	6.8*	6.8*	5.9*	5.9*	5.0*	5.0*											5.0*	5.0*	16.5		

Height Can be slewed through 360° In longitudinal position of undercarriage Max. reach * Limited by hydr. capacity

The lift capacities on the stick end without attachment are stated in metric tons (t) and are valid on a firm, level supporting surface with blocked oscillating axle. These capacities can be slewed through 360° with the undercarriage in the transverse position. Capacities in the longitudinal position of the undercarriage (±15°) are specified over the rigid axle with the stabilizers down. Indicated loads based on the ISO 10567 standard and do not exceed 75% of tipping or 87% of hydraulic capacity. The lift capacity values indicated are attained at the corresponding operating temperature. This operating temperature is ensured by continuous movement of the boom. Weights of fitted attachments (grabs, load hooks, etc.) and load accommodation attachment are to be deducted from the lift capacity values. The lift capacity of the unit is limited by its stability, the lifting capability of the hydraulic elements, or the maximum permissible lifting capacity of the load hook. In accordance with the harmonised European Standard EN 474-5, hydraulic excavators used for lifting operations must be equipped with pipe fracture safety valves, an overload warning device, a load hook and a lift capacity chart.

LH 60 M HR – Equipment AG23

Port – Kinematic 2D

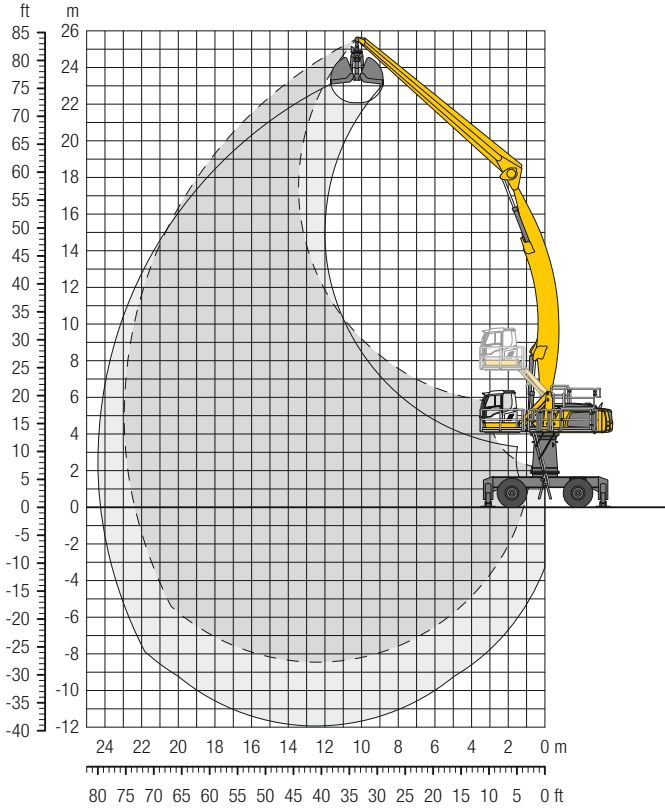

Dimensions

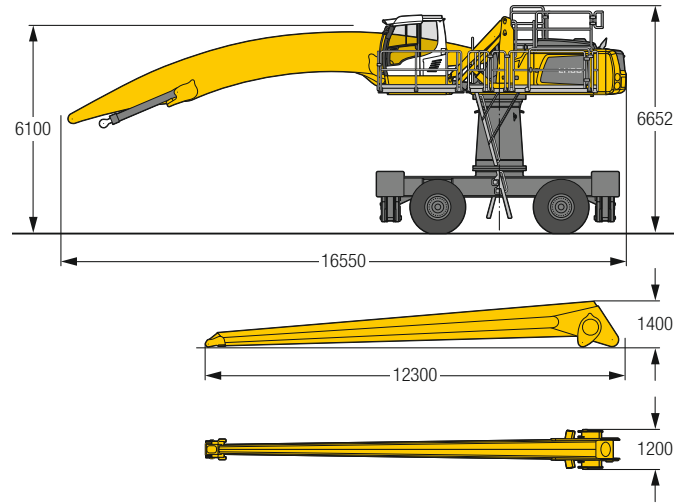

Operating weight

The operating weight includes the basic machine with 4 point outriggers, turret 2,000 mm, hydr. cab elevation, 4 solid tyres, angled boom 12.50 m, straight stick 11.80 m and grab for loose material GMZ 80 / 3.50 m³.

Weight 76,200 kg

m	Undercarriage	6.0 m		7.5 m		9.0 m		10.5 m		12.0 m		13.5 m		15.0 m		16.5 m		18.0 m		19.5 m		21.0 m		22.5 m		m				
		↙	↘	↙	↘	↙	↘	↙	↘	↙	↘	↙	↘	↙	↘	↙	↘	↙	↘	↙	↘	↙	↘	↙	↘	↙	↘			
25.5	4 pt. outriggers down																													
24.0	4 pt. outriggers down									6.4*	6.4*																6.3*	6.3*	10.4	
22.5	4 pt. outriggers down											6.4*	6.4*														5.1*	5.1*	14.9	
21.0	4 pt. outriggers down											7.0*	7.0*	6.3*	6.3*	4.9*	4.9*										4.8*	4.8*	16.5	
19.5	4 pt. outriggers down											6.9*	6.9*	6.5*	6.5*	6.0*	6.0*										4.6*	4.6*	17.9	
18.0	4 pt. outriggers down											6.9*	6.9*	6.4*	6.4*	6.0*	6.0*	5.6*	5.6*								4.5*	4.5*	19.0	
16.5	4 pt. outriggers down											6.9*	6.9*	6.4*	6.4*	6.0*	6.0*	5.7*	5.7*	4.9*	4.9*						4.4*	4.4*	19.9	
15.0	4 pt. outriggers down											6.9*	6.9*	6.4*	6.4*	6.0*	6.0*	5.7*	5.7*	5.4*	5.4*						4.3*	4.3*	20.7	
13.5	4 pt. outriggers down											7.0*	7.0*	6.5*	6.5*	6.1*	6.1*	5.7*	5.7*	5.4*	5.4*	4.8*	4.8*				4.3*	4.3*	21.4	
12.0	4 pt. outriggers down											7.1*	7.1*	6.6*	6.6*	6.1*	6.1*	5.7*	5.7*	5.4*	5.4*	5.1*	5.1*				4.3*	4.3*	21.9	
10.5	4 pt. outriggers down											8.0*	8.0*	7.3*	7.3*	6.7*	6.7*	6.2*	6.2*	5.8*	5.8*	5.5*	5.5*	5.1*	5.1*		4.3*	4.3*	22.3	
9.0	4 pt. outriggers down											8.3*	8.3*	7.5*	7.5*	6.9*	6.9*	6.3*	6.3*	5.9*	5.9*	5.5*	5.5*	5.2*	5.2*	4.6*	4.6*	4.4*	4.4*	22.6
7.5	4 pt. outriggers down											9.2*	9.2*	8.6*	8.6*	7.7*	7.7*	7.0*	7.0*	6.5*	6.5*	6.0*	6.0*	5.6*	5.6*	5.2*	5.2*	4.8*	4.8*	22.8
6.0	4 pt. outriggers down	17.2*	17.2*	13.9*	13.9*	11.7*	11.7*	10.1*	10.1*	8.9*	8.9*	8.0*	8.0*	7.2*	7.2*	6.6*	6.6*	6.1*	6.1*	5.6*	5.6*	5.2*	5.2*	4.8*	4.8*	4.6*	4.6*	4.6*	4.6*	22.9
4.5	4 pt. outriggers down	18.8*	18.8*	14.8*	14.8*	12.3*	12.3*	10.5*	10.5*	9.2*	9.2*	8.2*	8.2*	7.4*	7.4*	6.7*	6.7*	6.2*	6.2*	5.7*	5.7*	5.2*	5.2*	4.8*	4.8*	4.7*	4.7*	4.7*	4.7*	22.9
3.0	4 pt. outriggers down	17.4*	17.4*	15.6*	15.6*	12.8*	12.8*	10.9*	10.9*	9.5*	9.5*	8.4*	8.4*	7.5*	7.5*	6.8*	6.8*	6.2*	6.2*	5.7*	5.7*	5.2*	5.2*	4.8*	4.8*	4.6*	4.6*	4.6*	4.6*	22.8
1.5	4 pt. outriggers down	9.8*	9.8*	16.2*	16.2*	13.3*	13.3*	11.2*	11.2*	9.7*	9.7*	8.6*	8.6*	7.6*	7.6*	6.9*	6.9*	6.3*	6.3*	5.7*	5.7*	5.2*	5.2*	4.6*	4.6*	4.6*	4.6*	4.6*	4.6*	22.7
0	4 pt. outriggers down	8.1*	8.1*	14.3*	14.3*	13.5*	13.5*	11.4*	11.4*	9.9*	9.9*	8.7*	8.7*	7.7*	7.7*	6.9*	6.9*	6.3*	6.3*	5.7*	5.7*	5.1*	5.1*			4.5*	4.5*	4.5*	4.5*	22.4
-1.5	4 pt. outriggers down	7.7*	7.7*	12.0*	12.0*	13.5*	13.5*	11.5*	11.5*	9.9*	9.9*	8.7*	8.7*	7.7*	7.7*	6.9*	6.9*	6.2*	6.2*	5.5*	5.5*	4.9*	4.9*			4.4*	4.4*	4.4*	4.4*	22.0
-3.0	4 pt. outriggers down	7.7*	7.7*	11.2*	11.2*	13.3*	13.3*	11.3*	11.3*	9.8*	9.8*	8.6*	8.6*	7.6*	7.6*	6.7*	6.7*	6.0*	6.0*	5.3*	5.3*	4.6*	4.6*			4.3*	4.3*	4.3*	4.3*	21.5
-4.5	4 pt. outriggers down	8.0*	8.0*	11.1*	11.1*	12.8*	12.8*	11.0*	11.0*	9.5*	9.5*	8.3*	8.3*	7.3*	7.3*	6.5*	6.5*	5.7*	5.7*	4.9*	4.9*					4.1*	4.1*	4.1*	4.1*	20.8
-6.0	4 pt. outriggers down	8.4*	8.4*	11.2*	11.2*	12.0*	12.0*	10.3*	10.3*	9.0*	9.0*	7.8*	7.8*	6.9*	6.9*	6.0*	6.0*	5.2*	5.2*	4.3*	4.3*					4.2*	4.2*	4.2*	4.2*	19.6
-7.5	4 pt. outriggers down			10.7*	10.7*	9.3*	9.3*	8.1*	8.1*	7.1*	7.1*	6.2*	6.2*	5.3*	5.3*											5.0*	5.0*	5.0*	5.0*	17.0

Height Can be slewed through 360° In longitudinal position of undercarriage Max. reach * Limited by hydr. capacity

The lift capacities on the stick end without attachment are stated in metric tons (t) and are valid on a firm, level supporting surface with blocked oscillating axle. These capacities can be slewed through 360° with the undercarriage in the transverse position. Capacities in the longitudinal position of the undercarriage (±15°) are specified over the rigid axle with the stabilizers down. Indicated loads based on the ISO 10567 standard and do not exceed 75% of tipping or 87% of hydraulic capacity. The lift capacity values indicated are attained at the corresponding operating temperature. This operating temperature is ensured by continuous movement of the boom. Weights of fitted attachments (grabs, load hooks, etc.) and load accommodation attachment are to be deducted from the lift capacity values. The lift capacity of the unit is limited by its stability, the lifting capability of the hydraulic elements, or the maximum permissible lifting capacity of the load hook.

In accordance with the harmonised European Standard EN 474-5, hydraulic excavators used for lifting operations must be equipped with pipe fracture safety valves, an overload warning device, a load hook and a lift capacity chart.

LH 60 C HR – Equipment GG23

Port – Kinematic 2A

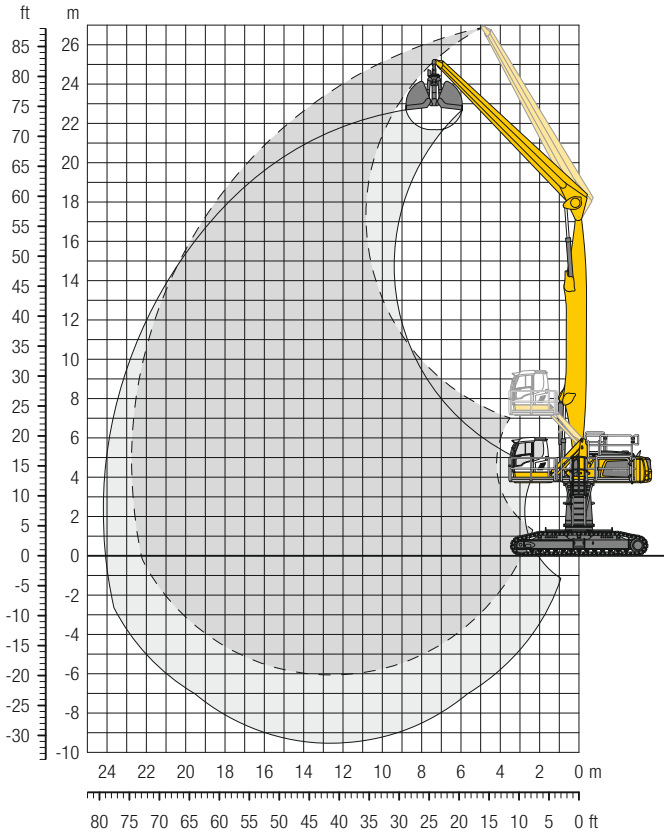

Dimensions

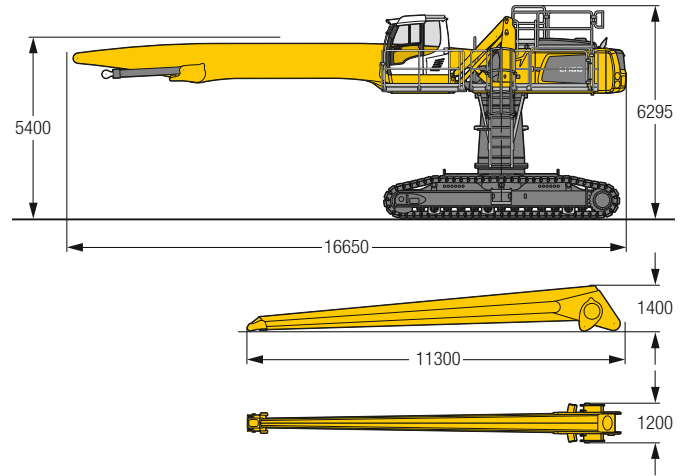

Operating weight and ground pressure

The operating weight includes the basic machine with turret 2,000 mm, hydr. cab elevation, straight boom 12.50 m, straight stick 10.80 m and grab for loose material GMZ 80 / 3.50 m³.

Weight	76,400 kg
Pad width	750 mm
Ground pressure	on request

m	Undercarriage	6.0m		7.5m		9.0m		10.5m		12.0m		13.5m		15.0m		16.5m		18.0m		19.5m		21.0m		22.5m		m				
		SW	SW	SW	SW	SW	SW	SW	SW	SW	SW	SW	SW	SW	SW	SW	SW	SW	SW	SW	SW	SW	SW	SW	SW	SW	SW			
25.5	SW			10.4*	10.4*	8.7*	8.7*																		8.5*	8.5*	9.1			
24.0	SW					10.1*	10.1*	8.9*	8.9*																	7.1*	7.1*	12.0		
22.5	SW							9.7*	9.7*	8.8*	8.8*	7.3*	7.3*													6.4*	6.4*	14.1		
21.0	SW							10.1*	10.1*	9.4*	9.4*	8.6*	8.6*	7.2*	7.2*											5.9*	5.9*	15.9		
19.5	SW									9.3*	9.3*	8.5*	8.5*	7.9*	7.9*	6.8*	6.8*										5.5*	5.5*	17.3	
18.0	SW									9.2*	9.2*	8.4*	8.4*	7.8*	7.8*	7.2*	7.2*	6.2*	6.2*								5.3*	5.3*	18.5	
16.5	SW									9.2*	9.2*	8.4*	8.4*	7.8*	7.8*	7.2*	7.2*	6.7*	6.7*								5.1*	5.1*	19.5	
15.0	SW									9.2*	9.2*	8.4*	8.4*	7.8*	7.8*	7.2*	7.2*	6.7*	6.7*	6.2*	6.2*						5.0*	5.0*	20.3	
13.5	SW							10.3*	10.3*	9.3*	9.3*	8.5*	8.5*	7.8*	7.8*	7.2*	7.2*	6.7*	6.7*	6.2*	6.2*						4.9*	4.9*	21.0	
12.0	SW							10.5*	10.5*	9.5*	9.5*	8.6*	8.6*	7.9*	7.9*	7.3*	7.3*	6.7*	6.7*	6.2*	6.2*	5.7*	5.7*				4.9*	4.9*	21.6	
10.5	SW							10.9*	10.9*	10.8*	10.8*	9.7*	9.7*	8.7*	8.7*	8.0*	8.0*	7.3*	7.3*	6.8*	6.8*	6.2*	6.2*	5.7*	5.7*		4.8*	4.8*	22.0	
9.0	SW									11.1*	11.1*	9.9*	9.9*	8.9*	8.9*	8.1*	8.1*	7.4*	7.4*	6.8*	6.8*	6.2*	6.2*	5.7*	5.7*		4.8*	4.8*	22.3	
7.5	SW											11.5*	11.5*	10.1*	10.1*	9.1*	9.1*	8.2*	8.2*	7.5*	7.5*	6.8*	6.8*	6.2*	6.2*	5.7*	5.7*	5.0*	5.0*	22.6
6.0	SW											10.4*	10.4*	9.2*	9.2*	8.3*	8.3*	7.5*	7.5*	6.8*	6.8*	6.2*	6.2*	5.6*	5.6*	4.9*	4.9*	4.7*	4.7*	22.7
4.5	SW											10.6*	10.6*	9.3*	9.3*	8.4*	8.4*	7.5*	7.5*	6.8*	6.8*	6.2*	6.2*	5.5*	5.5*	4.7*	4.7*	4.5*	4.5*	22.8
3.0	SW											10.7*	10.7*	9.4*	9.4*	8.4*	8.4*	7.5*	7.5*	6.8*	6.8*	6.1*	6.1*	5.4*	5.4*	4.4*	4.4*	4.3*	4.3*	22.7
1.5	SW											10.7*	10.7*	9.4*	9.4*	8.3*	8.3*	7.4*	7.4*	6.6*	6.6*	5.9*	5.9*	5.1*	5.1*	4.0*	4.0*	4.0*	4.0*	22.5
0	SW											10.6*	10.6*	9.2*	9.2*	8.2*	8.2*	7.2*	7.2*	6.4*	6.4*	5.6*	5.6*	4.7*	4.7*	3.6*	3.6*	3.6*	3.6*	22.3
-1.5	SW											10.2*	10.2*	8.9*	8.9*	7.9*	7.9*	6.9*	6.9*	6.0*	6.0*	5.2*	5.2*	4.1*	4.1*		3.7*	3.7*	21.4	
-3.0	SW											9.6*	9.6*	8.4*	8.4*	7.4*	7.4*	6.4*	6.4*	5.5*	5.5*	4.5*	4.5*				4.0*	4.0*	20.1	
-4.5	SW											8.7*	8.7*	7.6*	7.6*	6.6*	6.6*	5.6*	5.6*	4.7*	4.7*						4.5*	4.5*	18.2	
-6.0	SW											7.4*	7.4*	6.5*	6.5*												6.2*	6.2*	13.8	

Height Can be slewed through 360° In longitudinal position of undercarriage Max. reach * Limited by hydr. capacity

The lift capacities on the stick end without attachment are stated in metric tons (t) and can be slewed through 360° on a firm, level supporting surface. Capacities are valid for 750 mm wide flat pads. Indicated loads based on the ISO 10567 standard and do not exceed 75% of tipping or 87% of hydraulic capacity. The lift capacity values indicated are attained at the corresponding operating temperature. This operating temperature is ensured by continuous movement of the boom. Weights of fitted attachments (grabs, load hooks, etc.) and load accommodation attachment are to be deducted from the lift capacity values. The lift capacity of the unit is limited by its stability, the lifting capability of the hydraulic elements, or the maximum permissible lifting capacity of the load hook. In accordance with the harmonised European Standard EN 474-5, hydraulic excavators used for lifting operations must be equipped with pipe fracture safety valves, an overload warning device, a load hook and a lift capacity chart.

LH 60 C HR – Equipment AG22

Port – Kinematic 2D

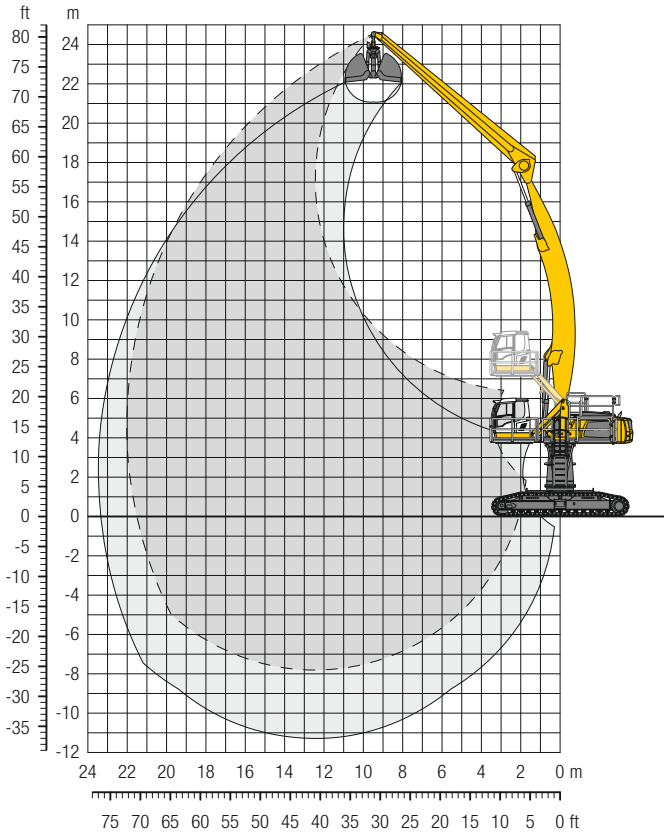

Dimensions

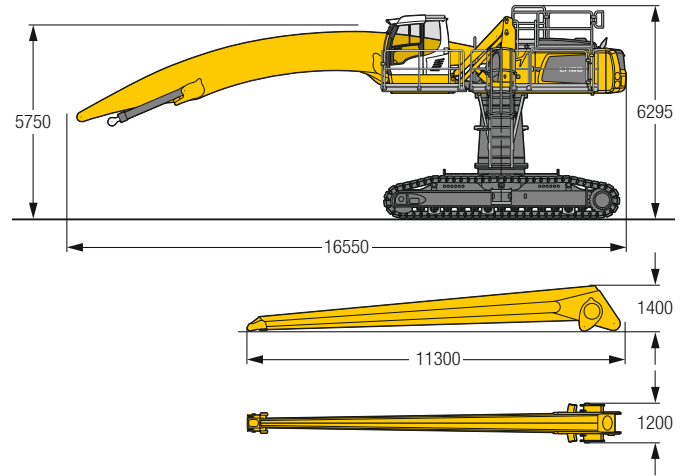

Operating weight and ground pressure

The operating weight includes the basic machine with turret 2,000 mm, hydr. cab elevation, angled boom 12.50 m, straight stick 10.80 m and grab for loose material GMZ 80 / 3.50 m³.

Weight	77,000 kg
Pad width	750 mm
Ground pressure	on request

m	Undercarriage	6.0m		7.5m		9.0m		10.5m		12.0m		13.5m		15.0m		16.5m		18.0m		19.5m		21.0m		22.5m		m		
		SW	SW	SW	SW	SW	SW	SW	SW	SW	SW	SW	SW	SW	SW	SW	SW	SW	SW	SW	SW	SW	SW	SW	SW	SW	SW	SW
24.0	SW							6.8*	6.8*																	6.7*	6.7*	10.6
22.5	SW									7.0*	7.0*															6.0*	6.0*	12.9
21.0	SW									8.0*	8.0*															5.6*	5.6*	14.8
19.5	SW											7.3*	7.3*	6.8*	6.8*											5.3*	5.3*	16.3
18.0	SW											7.2*	7.2*	6.7*	6.7*	6.3*	6.3*									5.1*	5.1*	17.6
16.5	SW											7.2*	7.2*	6.7*	6.7*	6.3*	6.3*	5.8*	5.8*							5.0*	5.0*	18.6
15.0	SW											7.2*	7.2*	6.7*	6.7*	6.3*	6.3*	5.9*	5.9*							4.9*	4.9*	19.5
13.5	SW								7.9*	7.9*	7.3*	7.3*	6.8*	6.8*	6.3*	6.3*	5.9*	5.9*	5.6*	5.6*						4.8*	4.8*	20.2
12.0	SW								8.1*	8.1*	7.4*	7.4*	6.8*	6.8*	6.4*	6.4*	6.0*	6.0*	5.6*	5.6*						4.8*	4.8*	20.8
10.5	SW							9.2*	9.2*	8.3*	8.3*	7.6*	7.6*	7.0*	7.0*	6.4*	6.4*	6.0*	6.0*	5.6*	5.6*	5.3*	5.3*			4.9*	4.9*	21.3
9.0	SW					10.9*	10.9*	9.6*	9.6*	8.6*	8.6*	7.8*	7.8*	7.1*	7.1*	6.5*	6.5*	6.1*	6.1*	5.7*	5.7*	5.3*	5.3*			4.9*	4.9*	21.6
7.5	SW			13.5*	13.5*	11.5*	11.5*	10.0*	10.0*	8.9*	8.9*	8.0*	8.0*	7.2*	7.2*	6.7*	6.7*	6.2*	6.2*	5.7*	5.7*	5.3*	5.3*			5.0*	5.0*	21.9
6.0	SW	18.0*	18.0*	14.4*	14.4*	12.1*	12.1*	10.4*	10.4*	9.2*	9.2*	8.2*	8.2*	7.4*	7.4*	6.8*	6.8*	6.2*	6.2*	5.8*	5.8*	5.3*	5.3*			5.1*	5.1*	22.0
4.5	SW	19.4*	19.4*	15.3*	15.3*	12.7*	12.7*	10.8*	10.8*	9.4*	9.4*	8.4*	8.4*	7.6*	7.6*	6.9*	6.9*	6.3*	6.3*	5.8*	5.8*	5.3*	5.3*			5.0*	5.0*	22.0
3.0	SW	12.1*	12.1*	16.0*	16.0*	13.2*	13.2*	11.2*	11.2*	9.7*	9.7*	8.6*	8.6*	7.7*	7.7*	7.0*	7.0*	6.4*	6.4*	5.8*	5.8*	5.3*	5.3*			5.0*	5.0*	22.0
1.5	SW	8.3*	8.3*	16.5*	16.5*	13.5*	13.5*	11.4*	11.4*	9.9*	9.9*	8.7*	8.7*	7.8*	7.8*	7.0*	7.0*	6.4*	6.4*	5.8*	5.8*	5.2*	5.2*			4.9*	4.9*	21.8
0	SW	7.4*	7.4*	12.7*	12.7*	13.7*	13.7*	11.6*	11.6*	10.0*	10.0*	8.8*	8.8*	7.8*	7.8*	7.0*	7.0*	6.3*	6.3*	5.7*	5.7*	5.1*	5.1*			4.8*	4.8*	21.5
-1.5	SW	7.3*	7.3*	11.3*	11.3*	13.7*	13.7*	11.6*	11.6*	10.0*	10.0*	8.8*	8.8*	7.8*	7.8*	7.0*	7.0*	6.2*	6.2*	5.5*	5.5*	4.8*	4.8*			4.7*	4.7*	21.1
-3.0	SW	7.6*	7.6*	10.9*	10.9*	13.3*	13.3*	11.4*	11.4*	9.8*	9.8*	8.6*	8.6*	7.6*	7.6*	6.8*	6.8*	6.0*	6.0*	5.2*	5.2*					4.6*	4.6*	20.6
-4.5	SW	8.1*	8.1*	11.0*	11.0*	12.7*	12.7*	10.9*	10.9*	9.5*	9.5*	8.3*	8.3*	7.3*	7.3*	6.4*	6.4*	5.6*	5.6*	4.7*	4.7*					4.3*	4.3*	20.0
-6.0	SW			11.4*	11.4*	11.7*	11.7*	10.1*	10.1*	8.8*	8.8*	7.7*	7.7*	6.8*	6.8*	5.9*	5.9*	4.9*	4.9*							4.6*	4.6*	18.5
-7.5	SW							9.0*	9.0*	7.9*	7.9*	6.8*	6.8*	5.9*	5.9*											5.9*	5.9*	15.1

Height Can be slewed through 360° In longitudinal position of undercarriage Max. reach * Limited by hydr. capacity

The lift capacities on the stick end without attachment are stated in metric tons (t) and can be slewed through 360° on a firm, level supporting surface. Capacities are valid for 750 mm wide flat pads. Indicated loads based on the ISO 10567 standard and do not exceed 75% of tipping or 87% of hydraulic capacity. The lift capacity values indicated are attained at the corresponding operating temperature. This operating temperature is ensured by continuous movement of the boom. Weights of fitted attachments (grabs, load hooks, etc.) and load accommodation attachment are to be deducted from the lift capacity values. The lift capacity of the unit is limited by its stability, the lifting capability of the hydraulic elements, or the maximum permissible lifting capacity of the load hook. In accordance with the harmonised European Standard EN 474-5, hydraulic excavators used for lifting operations must be equipped with pipe fracture safety valves, an overload warning device, a load hook and a lift capacity chart.

Liebherr ERC-System

More performance, less consumption

Lowering the equipment stores energy in the ERC-System. This stored energy is then made available to the machine to provide additional engine power. When the equipment is raised the stored energy is released and is reflected in powerful, homogeneous operating cycles. The result is a clear energy saving – and, at the same time, even greater performance.

System performance

The energy recovery cylinder is a storage system which is independent of the electric motor or diesel engine. The system performance of material handling machines fitted with the ERC-System is composed of the installed engine power and the energy recovery cylinder. When the equipment is raised, energy from the ERC-System is supplied in addition to the power from the engine.

ERC-System

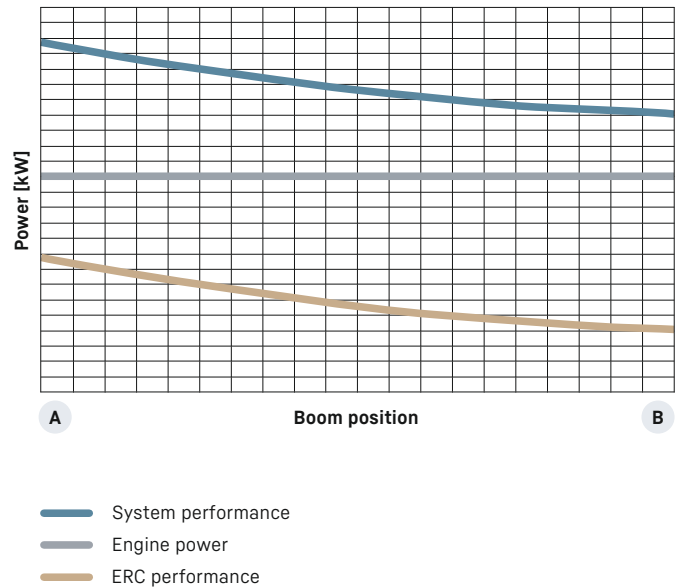

B 1. Equipment fitting raised / energy released

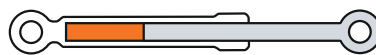

2. Lower equipment fitting / store energy
4. Raise equipment fitting / release energy



A 3. Equipment fitting lowered / energy stored

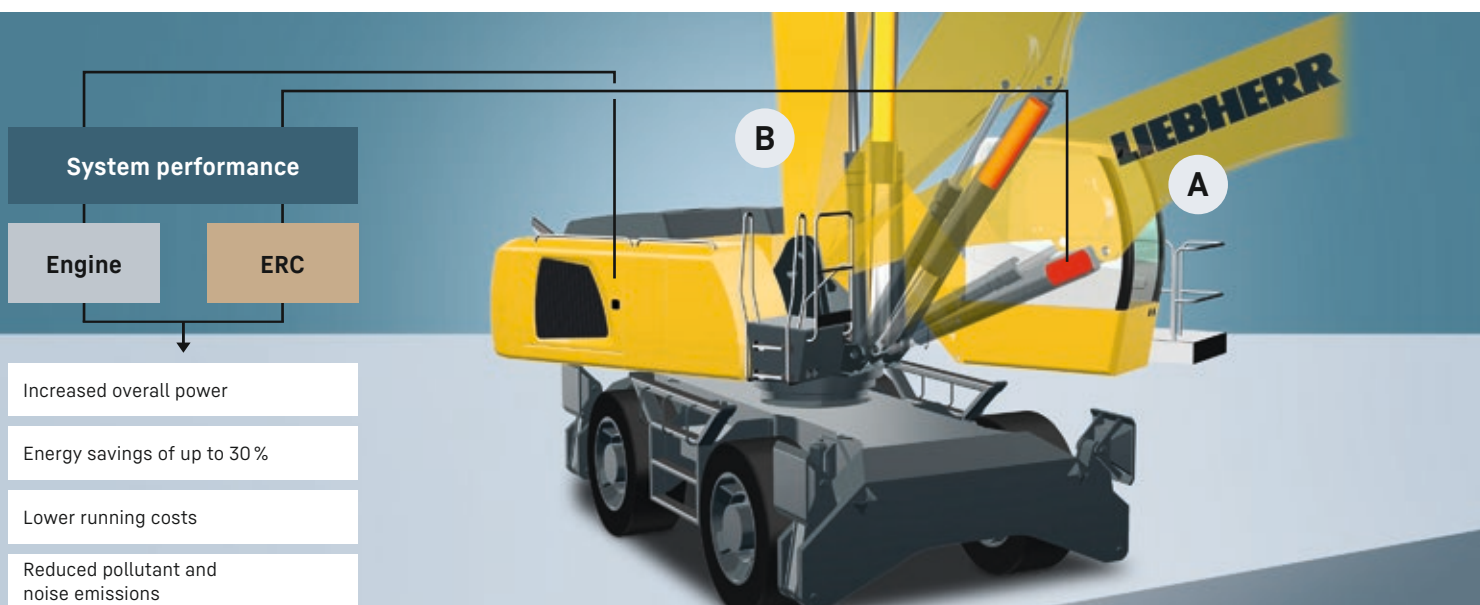

Attachments

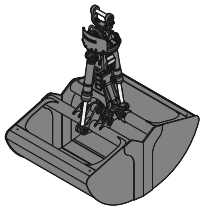

Grab for loose material

Shells for loose material with cutting edge (without teeth)

Grab model GMZ 50														
Width of shells	mm	1,400	1,600	1,800										
Capacity	m ³	3.50	4.00	4.50										
Max. material density	t/m ³	1.6	1.6	1.1										
Weight	kg	2,615	2,750	2,825										
Grab model GMZ 80														
Shell specification		Standard							Wide					
Width of shells	mm	1,300	1,500	1,750	2,000	2,200	2,600	3,000	3,400	1,300	1,500	1,700	2,000	2,200
Capacity	m ³	3.00	3.50	4.00	4.50	5.00	6.00	7.00	8.00	2.00	2.30	2.70	3.00	3.40
Weight	kg	2,510	2,625	2,775	2,920	3,255	3,490	3,720	3,955	2,310	2,400	2,535	2,670	2,895

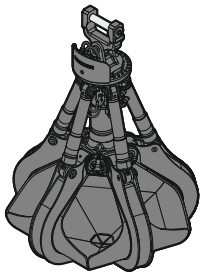

Multi-tine grab

closed, heart-shaped

Grab model GMM 80-5 (5 tines)											
Capacity	m ³	0.90	1.10				1.40			1.70	
Weight	kg	2,375	2,440				2,580			2,730	
Grab model GMM 120-5 (5 tines)											
Capacity	m ³	1.70	2.00				2.50			3.00	
Weight	kg	2,970	3,110				3,265			3,670	



Wood grab

Grab model GMH 50 – round overlapping (horizontal cylinders)													
Size	m ²	2.20	2.50			2.50		2.80		3.20		3.60	
Cutting width	mm	1,000	870			1,000		1,000		1,000		1,000	
Height of grab, closed	mm	2,323	2,416			2,416		2,521		2,649		2,814	
Weight	kg	2,135	2,105			2,180		2,260		2,320		2,375	
Grab model GMH 80 – round overlapping (vertical cylinders)													
Size	m ²	1.30	1.60			1.90		2.20		2.50			
Cutting width	mm	870	870			870		870		870			
Height of grab, closed	mm	2,805	2,905			2,983		3,065		3,142			
Weight	kg	2,155	2,215			2,260		2,295		2,335			

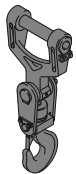

Load hook

Max. load	t	12,5
Height with suspension	mm	930
Weight	kg	135

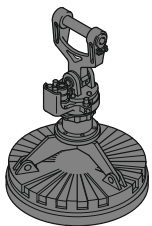



Magnet devices / lifting magnets

Generator	kW	13 / 20 / 25
Electromagnet with suspension		
Power	kW	12,8 / 17,8
Diameter of magnet	mm	1,700
Weight	kg	3,280*

* only magnet plate

Equipment

	60 M	60 C	60 M HR	60 C HR
 Undercarriage				
Track pads, variants		+		+
Individual control outriggers	+		•	
Three-piece chain guide		•		•
Shuttle axle lock, automatic	•		•	
Outrigger monitoring system	+		+	
Tyres, variants	+		+	
Trailing cable ²⁾	•	•	•	•
Protection for piston rods, outriggers	+		+	
Two storage compartments ¹⁾	•			
One storage compartment ²⁾	•			
Cable reel system ²⁾	+		+	+

	60 M	60 C	60 M HR	60 C HR
 Uppercarriage				
Uppercarriage right side light, 1 piece, LED	•	•	•	•
Uppercarriage rear light, 2 pieces, LED	+	+		
Uppercarriage underneath rear light, 1 piece, LED			+	+
Refuelling system with filling pump ¹⁾	+	+	+	+
Railing on uppercarriage	+	+	•	•
Generator	+	+	+	+
Main battery switch for electrical system	•	•	•	•
Amber beacon, at uppercarriage, LED double flash	+	+	+	+
Protection for headlights	+	+		
Protection for rear lights	+	+		
Tool equipment, extended	•	•	•	•

	60 M	60 C	60 M HR	60 C HR
 Hydraulic system				
Electronic pump regulation	•	•	•	•
Liebherr hydraulic oil from -20 °C to +40 °C	•	•	•	•
Liebherr hydraulic oil, biologically degradable	+	+	+	+
Liebherr hydraulic oil, specially for warm or cold regions	+	+	+	+
Magnetic rod in hydraulic tank	•	•	•	•
Bypass filter	+	+	+	+
Preheating hydraulic oil	+	+	+	+

	60 M	60 C	60 M HR	60 C HR
 Engine				
Fuel anti-theft device ¹⁾	+	+	+	+
Air pre-filter with dust discharge ¹⁾	+	+	+	+
Automatic engine shut-down (time adjustable)	+	+	+	+
Preheating fuel ¹⁾	+	+	+	+
Preheating coolant ¹⁾	+	+	+	+
Preheating engine oil* ¹⁾	+	+	+	+

	60 M	60 C	60 M HR	60 C HR
 Cooling system				
Reversible fan drive	+	+	+	+
Protective grid in front of cooler intake	•	•	•	•



Cab

	60 M	60 C	60 M HR	60 C HR
Stabilizer, control lever, left console	+		+	
Stabilizer, proportional control on left joystick	●		●	
Cab lights rear, LED	+	+	+	+
Cab lights front, LED	+	+	+	+
Cab lights front, LED (under rain cover)	●	●	●	●
Armrest adjustable	●	●	●	●
Circular bubble level	+	+	+	●
Slewing gear brake Comfort, button on the left or right joystick	+	+	+	+
Driver profile, personalised (max. 5 drivers)	+	+	+	+
Operator's seat Comfort	●	●	●	●
Operator's seat Premium	+	+	+	+
Driving alarm				
(acoustic signal is emitted during travel, can be switched ON/OFF)	+	+	+	+
Fire extinguisher	+	+	+	+
Footrest	+	+	+	+
Horn, button on left joystick	●	●	●	●
Joystick steering	●		●	
Joystick and wheel steering (slim version)	+	+	+	
Cab elevation, hydraulic (LHC)	●	●	●	●
Cab elevation, hydraulic with double parallelogram (LHC-D)			+	+
Cab elevation, rigid (LFC)	+	+		
Automatic air conditioning	●	●	●	●
Wheel steering (slim version)	+		+	
LiDAT, vehicle fleet management	●	●	●	●
Engine shut-down (emergency stop) cab ²⁾	●	●	●	●
Proportional control	●	●	●	●
Radio Comfort, control via display with handsfree set	+	+	+	+
Preparation for radio installation	●	●	●	●
Back-up alarm				
(acoustic signal is emitted traveling backward, can not be switched off)	+		+	
Amber beacon, on cab, LED double flash	+	+	+	+
Windows made from impact-resistant laminated safety glass	+	+	●	●
Windscreen wiper, roof	+	+	+	+
Windshield wiper, entire windscreen	●	●	●	●
FOPS top guard	+	+	+	+
FGPS front guard, tiltable	+	+	+	+
Sun visor	+	+	+	+
Stationary air-conditioning ²⁾	●	●	●	●
Left control console, folding	●	●	●	●



Equipment

	60 M	60 C	60 M HR	60 C HR
Boom lights, 2 pieces, LED	●	●	●	●
Stick lights, 2 pieces, LED	●	●	●	●
Boom shutoff (retract/extend), electronically	+	+	●	●
Equipment with electro-hydraulic end position control	●	●	●	●
AutoLift	+	+	+	+
Pressure warning mechanism hoist cylinder	●	●	●	●
ERC system	●	●	●	●
Filter system for attachment	+	+	+	+
Electronic lift limitation	+	+	+	+
Boom cylinder cushioning	●	●	●	●
Stick camera (with separate monitor), bottom side, with protection	+	+	+	+
Load torque limitation	+	+	+	+
Liebherr multi coupling system	+	+	+	+
Pipe fracture safety valves hoist cylinders	●	●	●	●
Pipe fracture safety valves stick cylinders	●	●	●	●
Quick coupling system MH 110B	+	+	+	+
Protection for piston rod, energy recovering cylinder	+	+	+	+
Protection for piston rods, hoist cylinder	+	+	+	+
Stick shutoff (retract), electronically	●	●	●	●
Stick shutoff (retract/extend), electronically	+	+	●	●
Retract stick without pressure	●	●	●	●
Sticks with quick coupling	+	+	+	+
Overload warning device	+	+	+	+



Complete machine

	60 M	60 C	60 M HR	60 C HR
Lubrication				
Lubrication undercarriage, manually - decentralised (grease points)	●			
Lubrication undercarriage, manually - centralised (one grease point)	+		●	
Central lubrication system for uppercarriage and equipment, automatically	●	●	●	●
Central lubrication system for undercarriage, automatically	+		+	
Centralised lubrication extended for attachment	+	+	+	+
Special coating				
Special coating, variants	+	+	+	+
Monitoring				
Rear view monitoring with camera	●	●	●	●
Side view monitoring with camera	●	●	●	●

● = Standard, + = Option

* = country-dependent, ¹⁾ not with electric drive, ²⁾ only with electric drive

Options and / or special equipment, supplied by vendors other than Liebherr, are only to be installed with the knowledge and approval of Liebherr in order to retain warranty.

