GMP 25

Parallel grab

LIEBHERR

Attachment



Parallel grab GMP 25

Pole clamp

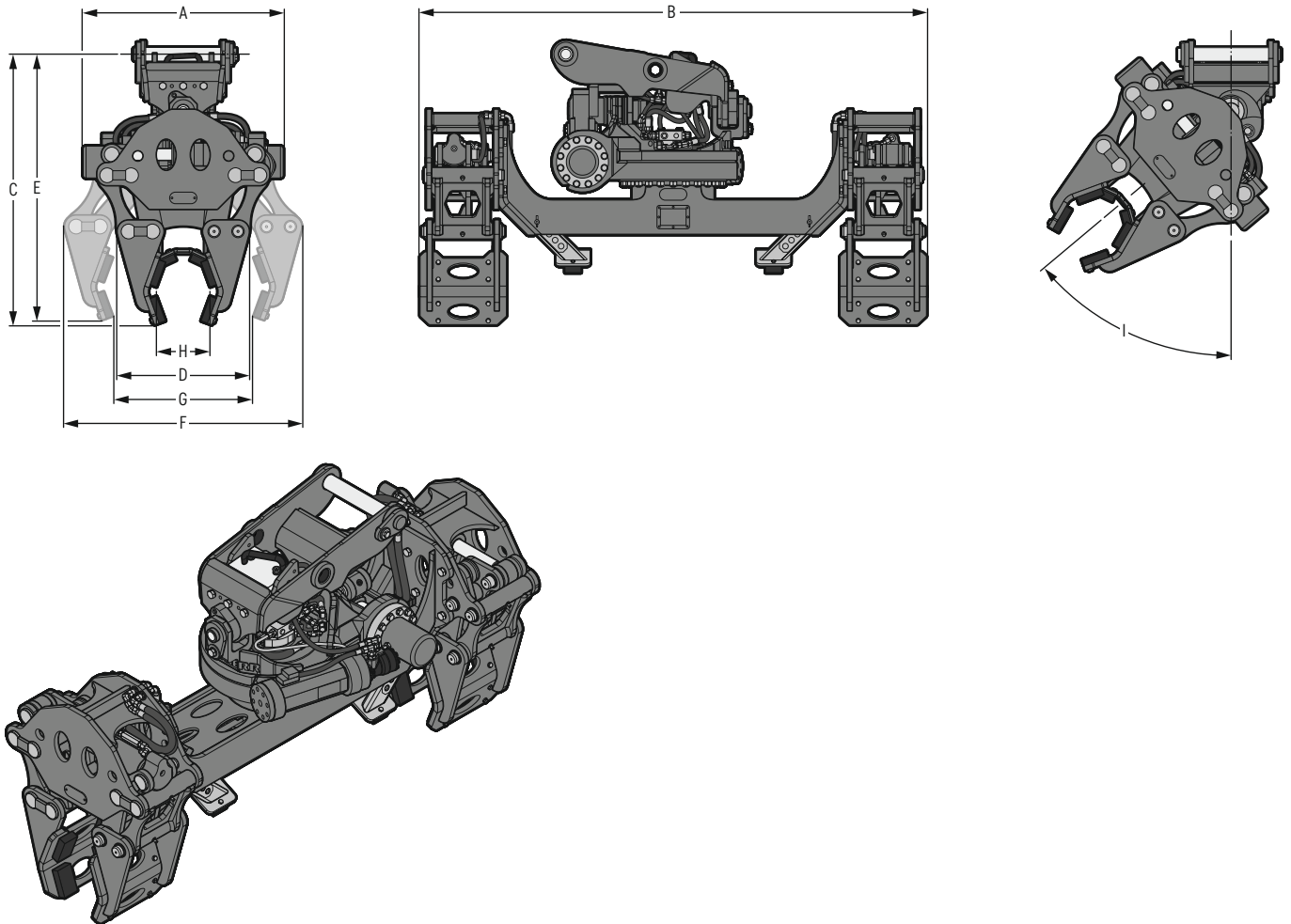

Machine range

Liebherr machines	
Wheeled excavator - Compact	A 918 Compact
Wheeled excavator	A 916 - A 920
Crawler excavator - Compact	R 920 Compact - R 926 Compact
Crawler excavator	R 918 - R 920
Railroad excavator	A 922 Rail, A 924 Rail

Other machine makes	
Weight class	approx. 18-24 t
(see operating manual for exact specification)	

Dimensions / weights

A Width	B Length	C Height closed	D Clamp width closed	E Height open	F Clamp width open	G Clamp diameter max.	H Clamp diameter min.	I Tilt angle	Weight ¹⁾
880 mm	2.230 mm	1.195 mm	585 mm	1.170 mm	1.045 mm	600 mm	250 mm	± 50°	1.470 kg

¹⁾ incl. SWA Solidlink 33-9 quick coupler mounting

Technical data

Rotary drive		Tilting drive		Grab open / close		Lift capacity max.
Hydraulic pressure max.	Flow rate max.	Hydraulic pressure max.	Flow rate max.	Pressure max.	Flow max.	
15 MPa / 150 bar	50 l/min.	35 MPa / 350 bar	200 l/min.	35 MPa / 350 bar	200 l/min.	5 t

Safety

The EuroTest certificate for the Liebherr GMP 25 parallel grab was awarded by the DGUV Test testing and certification centre for the construction industry.

Equipment

Mounting

SW stick
SWA Solidlink 33-9

GMP 25¹⁾
+
●

¹⁾ on the machine side, a 14-pin signal contact strip and a power socket on the stick, switchable via signal contacts are always required

● = Standard, + = Option

The Liebherr Group



Global and independent: more than 70 years of success

Liebherr was founded in 1949 when, with the development of the world's first mobile tower crane, Hans Liebherr laid the foundations for a family-run company which now has more than 50,000 employees and comprises over 150 companies across every continent. The holding company of the Group is Liebherr-International AG in Bulle, Switzerland, whose shareholders are exclusively members of the Liebherr family.

Technology leadership and pioneering spirit

Liebherr is a pioneer and its forward-looking approach has seen it make important contributions to technology history over a wide variety of industries. Employees throughout the world continue to share the courage of the company founder, sharing a passion to produce innovative products and a determination to provide world-leading equipment and machinery.

Diversified product programme

Liebherr is one of the world's biggest construction machine manufacturers and provides high-quality, user-oriented products and services. Its product programme includes earthmoving machinery, material handling technology, deep foundation machines, mining, mobile and crawler cranes, tower cranes, concrete technology, maritime cranes, aerospace and transportation systems, gear technology and automation systems, refrigerators and freezers, components and hotels.

Customised solutions and maximum customer value

Liebherr solutions are characterised by precision, implementation and longevity. The company is committed to technological excellence and to providing customers with solutions that match their needs exactly. For Liebherr, customer focus does not end with delivery of a product but continues through a comprehensive range of back-up and support services.

www.liebherr.com

Liebherr-Hydraulikbagger GmbH

Liebherrstraße 12 • 88457 Kirchdorf (Iller), Germany • Phone +49 7354 80-0
info.lhb@liebherr.com • www.liebherr.com • www.facebook.com/LiebherrConstruction