

EN

LR 1130.1

LR 1002.04.08
www.liebherr.com

LIEBHERR

Crawler cranes



Concept and characteristics	3
Technical description	6
Dimensions	8
Transport dimensions and weights	9
Self-assembly system	12
Boom combinations	14
Main boom 2017.xx	16
Luffing jib 1309.xx	18
Fixed jib 0806.xx	24

Remarks

- The load capacities stated are valid for lifting operation only (corresponding with crane classification according to ISO 4301-1, crane group A1).
- Machine is standing on firm, horizontal ground.
- The weight of the lifting device (pulley block, hoist ropes, shackles etc.) must be deducted from the load capacity.
- Additional equipment on boom (e.g. walkways) must be deducted from the load capacity.
- The max. admissible wind speed can be preselected in the LML software and referred to in the load chart.
- Working radii are measured from centre of swing ring and under load.
- The lifting capacities are valid for 360 degrees of swing.
- Calculation of stability under load is based on ISO 4305 Table 1 + 2 + 3, tipping angle 4°.
- The steel structures are calculated according to EN 13001-1; EN 13001-2.
- The last digits of the given dimensions are rounded to 0 and 5 and may differ from the actual dimensions.
- Weights may vary depending on the delivered configuration of the machine filling level of the tanks as well as generally valid tolerances.
- The illustrations in this brochure may include options which are not within the standard scope of supply of the machine.

Concept and characteristics

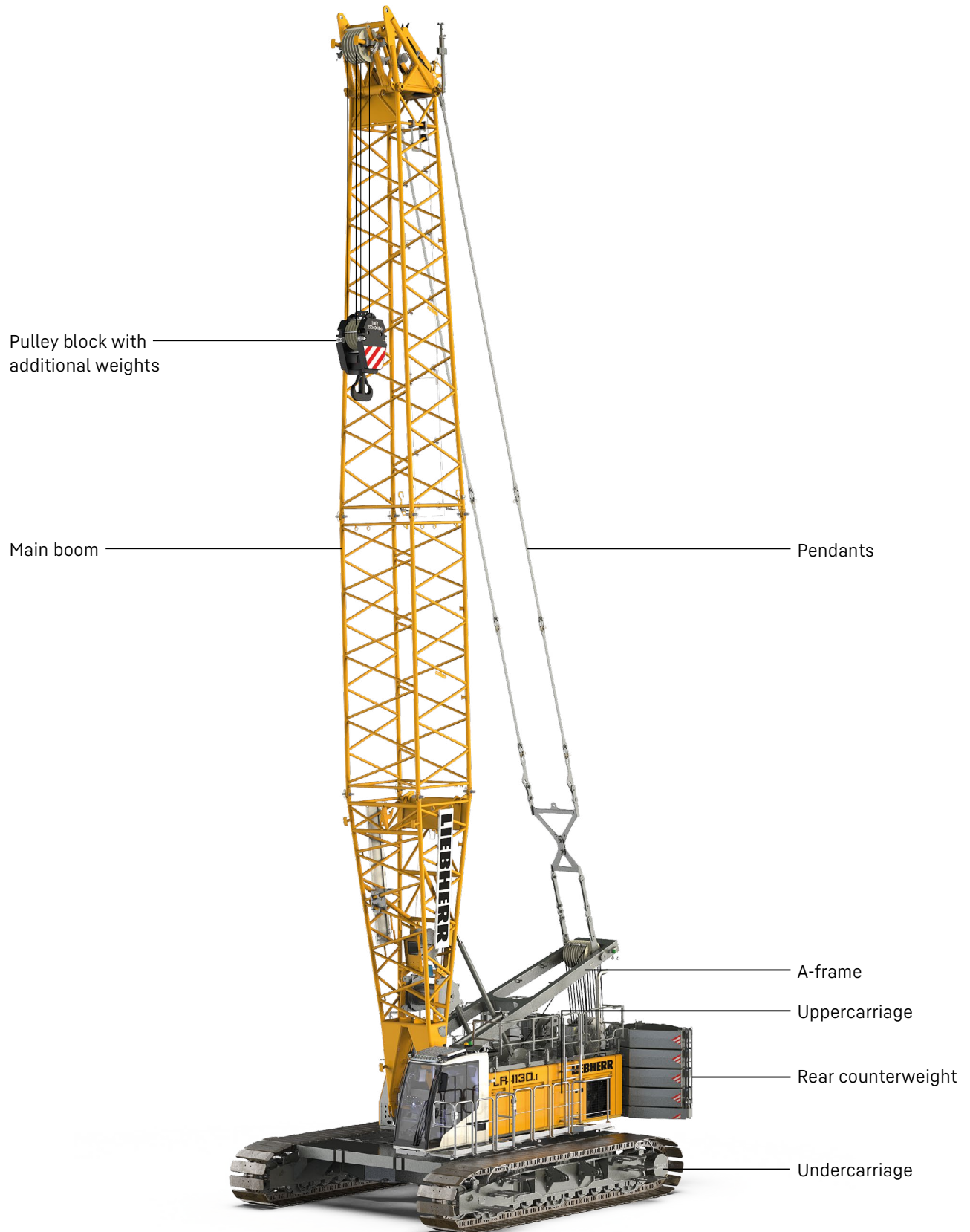

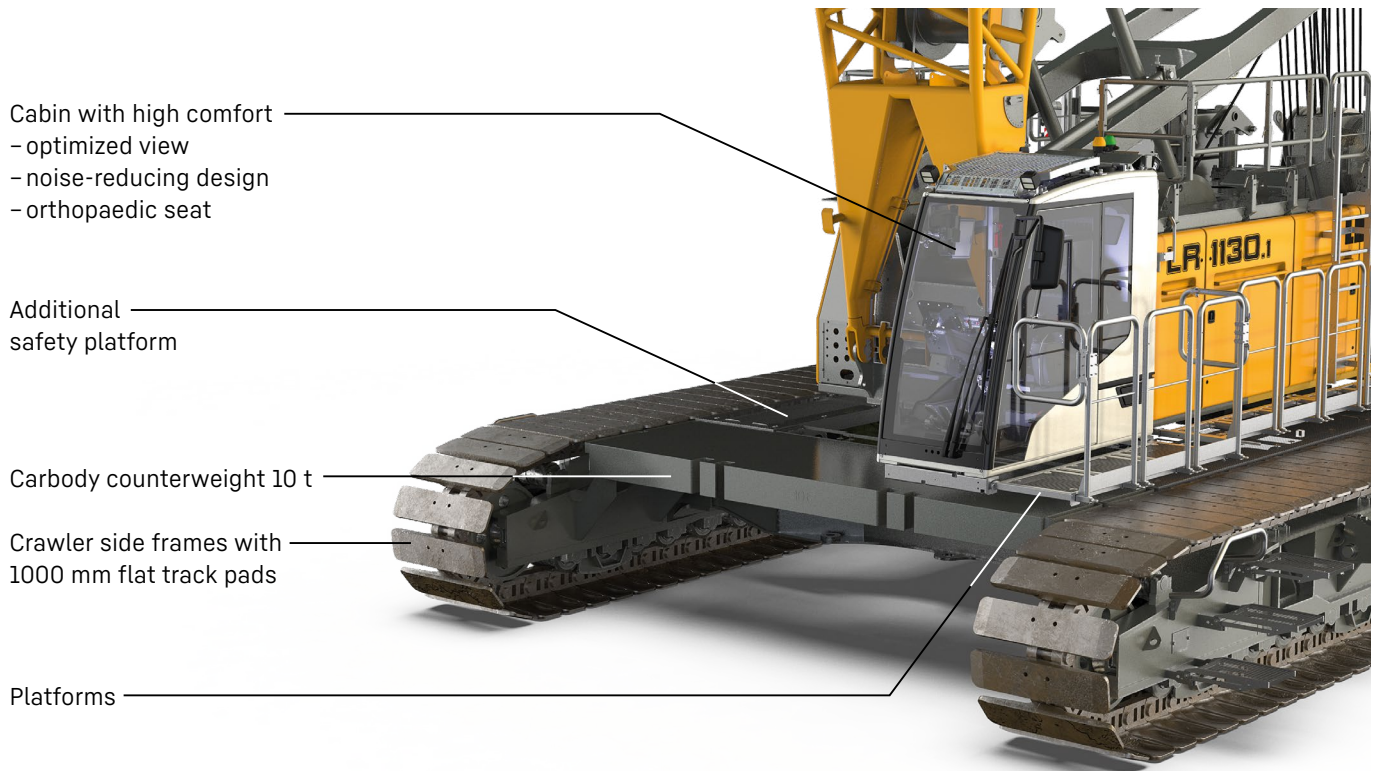

High performance

A strong, efficient and reliable diesel engine of the newest generation provides high performance and enables several movements to be carried out simultaneously.

Ground pressure

The actual ground pressure is calculated according to the configuration and position of the machine and displayed in the operator’s cabin. Using the optional Liebherr Crane-Planner the actual ground pressure can already be calculated and displayed in the planning stage.

Cabin with high comfort

Optimised field of vision combined with enhanced comfort: an orthopaedic operator’s seat with heating and cooling functions, as well as precise and ergonomic controls are included.

Control

Easy and intuitive handling of control, service and machine functions through a large, clear colour monitor. Built for extreme environmental conditions.

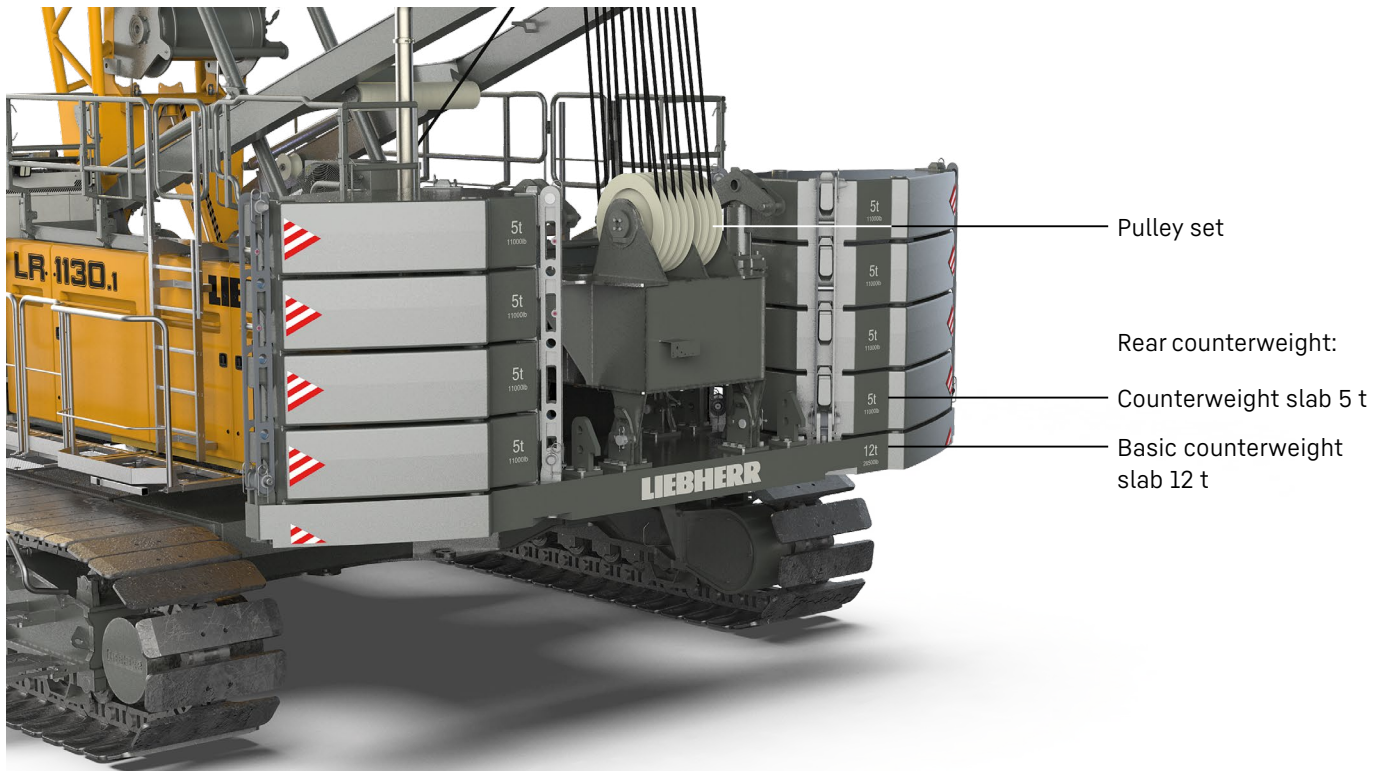

Efficient self-assembly system and short assembly times

The self-assembly system enables safe, independent and quick assembly/disassembly of the crawler side frames, the carbody and rear counterweights, as well as boom elements.

Mobility

Crane parts are optimized for transportation. The maximum transport width is 3 m.

Easy service

The design ensures easy maintenance and service as well as safe access to the components.

Boom

A variety of boom systems and configurations allow for optimum operation on the most diverse jobsites.

Technical description



Diesel engine

Power rating according to ISO 9249	230 kW (308 hp) at 1700 rpm
Engine type	Liebherr D 944 A7-05
Fuel tank capacity	790 l with continuous level indicator and reserve warning
Exhaust certification	97/68 EC Stage IV; EPA/CARB Tier 4f 97/68 EC Stage V; EPA/CARB Tier 4f ECE-R.96 Power Band H non-certified emission standard



Noise measurement data and vibration

Noise emission	according to 2000/14/EC directive	
Emission sound pressure level L_{PA}	73.0 dB(A)	(in the cabin)
Guaranteed sound power level L_{WA}	104 dB(A)	(of the machine)
Vibration transmitted to the machine operator	< 2.5 m/s ²	(to the hand-arm system)
	< 0.5 m/s ²	(to the whole body)



Hydraulic system

Hydraulic pumps	double axial displacement pump in open loop hydraulic system allows all functions to be operated simultaneously automatic working pressure cut-off to minimize peak pressure
Hydraulic oil tank capacity	650 l
Max. working pressure	350 bar
Hydraulic oil	electronic monitoring of alle filters use of synthetic environmentally friendly oil



Control

Control system	includes all control and monitoring functions, designed to withstand extreme environmental conditions and heavy construction tasks
Display	high resolution monitor in the operator's cabin, clear display of complete machine operating data, warnings and failure indications in the required language
Operation	several movements can be performed simultaneously thanks to electro-hydraulic proportional control, all categories of loads can be positioned with utmost precision



Crawlers

Drive system	with fixed axial piston hydraulic motors
Crawler side frames	maintenance-free, with hydraulic chain tensioning device
Brake	hydraulically released, spring-loaded multi-disc holding brake
Drive speed	0-2.1 km/h
Flat track pads	width 1000 mm



Swing gear

Drive system	with fixed axial piston hydraulic motors, planetary gearbox, pinion
Swing ring	roller bearing with external teeth
Brake	hydraulically released, spring-loaded multi-disc holding brake
Swing speed	0-3 rpm continuously variable
Speed control	both swing modes are possible - speed control or free swing for speed control: a multi-disc holding brake locks automatically at zero swing motion.



Hoisting gear

Standard crane winches 1 + 2	internal low-maintenance planetary gearbox in oil bath, load support by the hydraulic system, spring-loaded, multi-disc holding brake, pressure controlled, variable flow hydraulic motors for the main winches, full utilisation of engine power as the winch speed is automatically adjusted to suit the respective line pull
Line pull in the 7th layer	120 kN
Rope diameter	26 mm
Drum diameter	580 mm
Rope speed	0-136 m/min
Rope capacity in 7 layers	489 m
Option - winch with free fall	free fall: clutch and braking functions are provided by the service brake (low wear and maintenance-free multi-disc brake in compact design)







Boom/jib luffing winches

Main boom	
Line pull	max. 180 kN
Rope diameter	24 mm
Boom luffing	15-86° in 96 s
Jib	
Line pull	max. 105 kN
Rope diameter	20 mm
Jib luffing	15-78° in 46 s

Operating weight

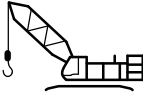
Composition of operating weight	basic machine with crawlers winches 1 + 2, A-frame 17 m main boom, consisting of boom foot (7 m) and boom head (10 m) 52.3 t rear counterweight (8 × 5 t + 1 × 12 t + 0.3 t) 20 t carbody counterweight (2 × 10 t) 160 t pulley block
Total weight	approx. 146.1 t

Operation modes

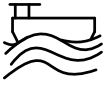
	 Lifting mode	 Grab mode	 Personnel lifting mode
 Land	✓	✓	✓
 Floating structure (barge operation)	✓	✓	✓ *

* only valid for jack-up barges

Optional equipment

Basic machine

Main winches 12 t with free fall
Painting in customer design
Load hook 12.5 / 40 / 80 / 100 / 160 t

Economy and ecology

Eco-Silent Package
Aux. power unit (APU, 2.8 kW)

Boom/jib

Luffing jib: luffing winch

Boom/jib other

Walkways for main boom sections 3 / 6 / 12 m

Application packages

Operation mode: personnel lifting (O)
Operation mode: barge operation (O)
Operation mode: foundation work (O)
Operation mode: wind speed pre-selection (S)
Operation mode: travelling with load (S)

Winch synchronization

Radio remote control
Rope reeving function via radio remote control

Assembly radio remote control

Use of luffing jib winch as auxiliary winch
Tagline winch 2 t free fall
Main winch constant tension for one winch
Two hook operation

Special features

Crane Planner 2.0
LiDAT

Self-assembly system

Jack-up system standard / telescopic
Self-assembly system counterweight
Self-assembly cylinder
Reeving winch

Service package

Refuelling pump diesel / AdBlue
Cold package -25 °C / -40 °C
Hydraulic oil bypass filter
Central lubrication swing ring bearings / outside
Liebherr hydraulic oil plus (longlife & bio)
Liebherr hydraulic oil plus arctic (longlife & bio)
Liebherr hydraulic oil plus arctic (longlife)

Safety features

Assistance system: Boom Up-and-Down Assistant
Assistance system: Horizontal Load Path
Assistance system: Vertical Line Finder
Assistance system: Ground Pressure Indication and Visualization
Rear and side view cameras
Winch camera
Zoom camera at boom head section
Platforms and railings on uppercarriage 580 mm
Additional access ladder for boom assembly
Railings on rooftop foldable
Railings for cabin platform
Vandalism cabin protection
Cabin protection roof, FOPS level 1
Lifting height indication for both hoist winches
Plug&Play diesel-hydraulic back-up unit 18.4 kW
Swing and boom radius limit device
Aircraft warning light
Swing warning light
Lightning rod
Mechanical angle display
Air intake shut-off valve
Access control

Operator's comfort

Additional access ladder
Additional floodlights
Cabin air conditioner
Cabin tilting device hydraulic
Gear oil level warning
Litronic additional language
Storage box for tools (crawler side frame)

(S) standard, (O) option

Dimensions

Basic machine with undercarriage

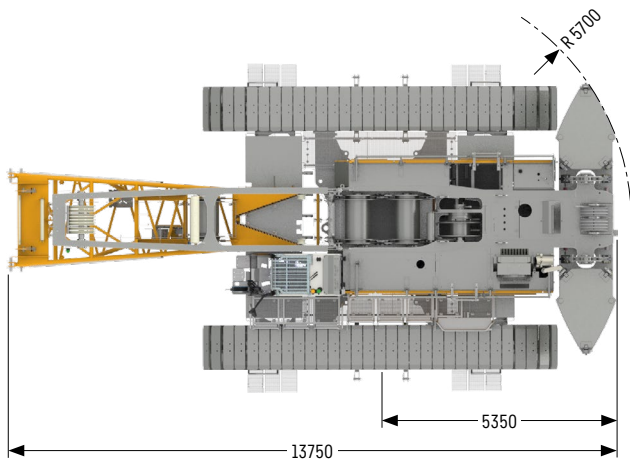
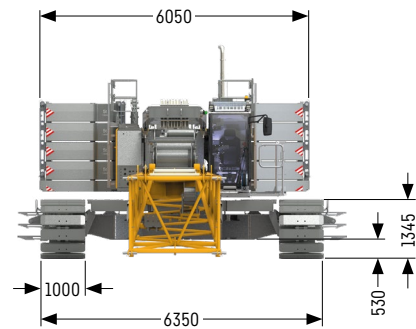
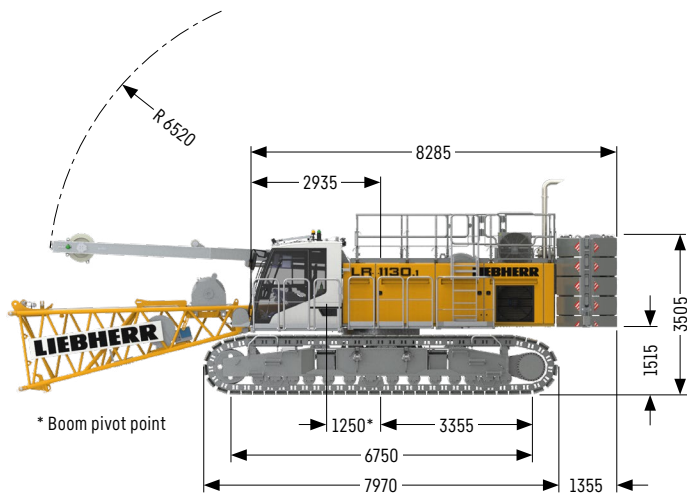

Transport dimensions and weights

Basic machine and boom 2017.xx

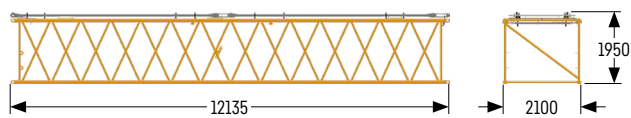
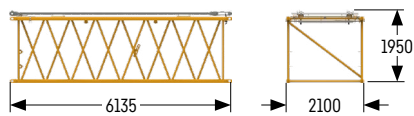
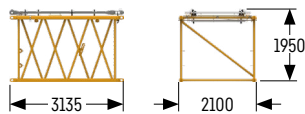
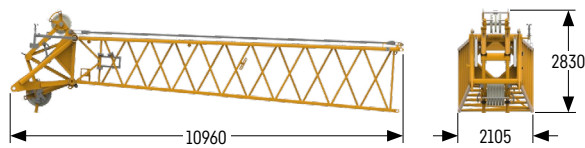
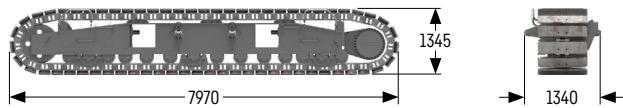
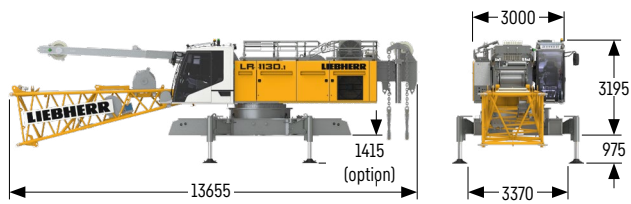

Basic machine

Weight without hoist rope	kg	33400
Weight of hoist ropes	kg/m	3.4
with A-frame 1, winches 1 + 2 (2x 120 kN), with boom foot, without rear counterweight, without carbody counterweight and crawler side frames		

Crawler side frame

Weight flat track pads 1000 mm	kg	16000
--------------------------------	----	-------

Boom head 10 m (No. 2017.21)

Weight including boom pendants	kg	3000
--------------------------------	----	------

Boom section 3 m (No. 2017.21)

Weight including boom pendants	kg	570
Weight incl. boom and jib pendants	kg	640

Boom section 6 m (No. 2017.21)

Weight including boom pendants	kg	930
Weight incl. boom and jib pendants	kg	1016

Boom section 12 m (No. 2017.21)

Weight including boom pendants	kg	1655
Weight incl. boom and jib pendants	kg	1870

Transport option 2017.xx / 1309.xx

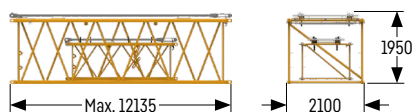

Transport option (No. 2017.xx / 1309.xx)

No. 2017.xx / 1309.xx	m	6 / 6	12 / 11.7
Weight including pendants	kg	1580	2830

Fixed jib 0806.xx

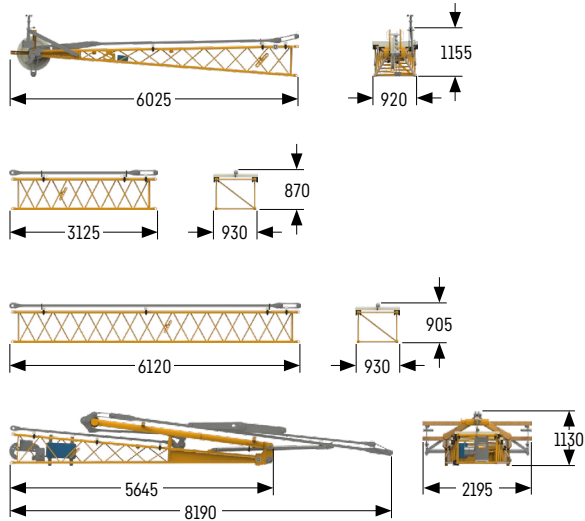

Jib head 5.5 m (No. 0806.16)

Weight including pendants	kg 442
---------------------------	--------

Jib section 3 m (No. 0806.15)

Weight including pendants	kg 141
---------------------------	--------

Jib section 6 m (No. 0806.15)

Weight including pendants	kg 249
---------------------------	--------

Jib foot 5.5 m with A-frame (No. 0806.16)

Weight including pendants	kg 1122
---------------------------	---------

Luffing jib 1309.xx

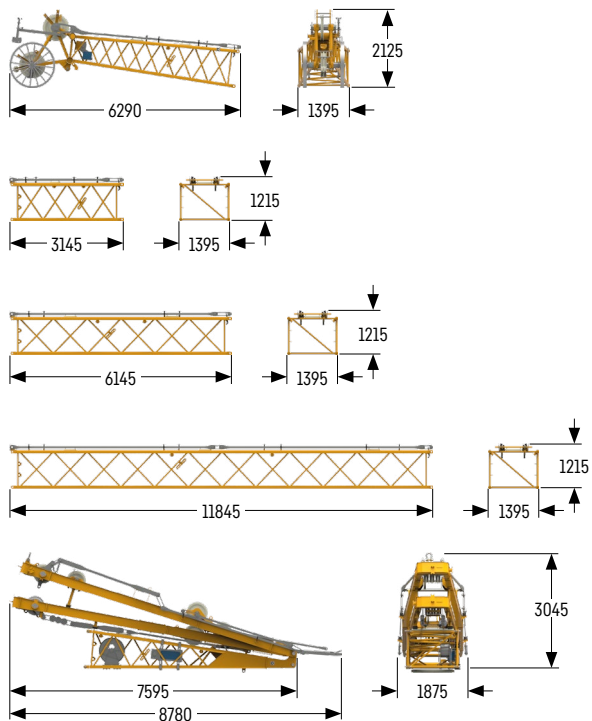

Jib head 5.5 m (No. 1309.22)

Weight including pendants	kg 1127
---------------------------	---------

Jib section 3 m (No. 1309.20)

Weight including pendants	kg 307
---------------------------	--------

Jib section 6 m (No. 1309.20)

Weight including pendants	kg 511
---------------------------	--------

Jib section 11.7 m (No. 1309.20)

Weight including pendants	kg 941
---------------------------	--------

Jib foot 5.5 m with A-frames 2 + 3 (No. 1309.22)

Weight including pendants	kg 4553
---------------------------	---------

Counterweight

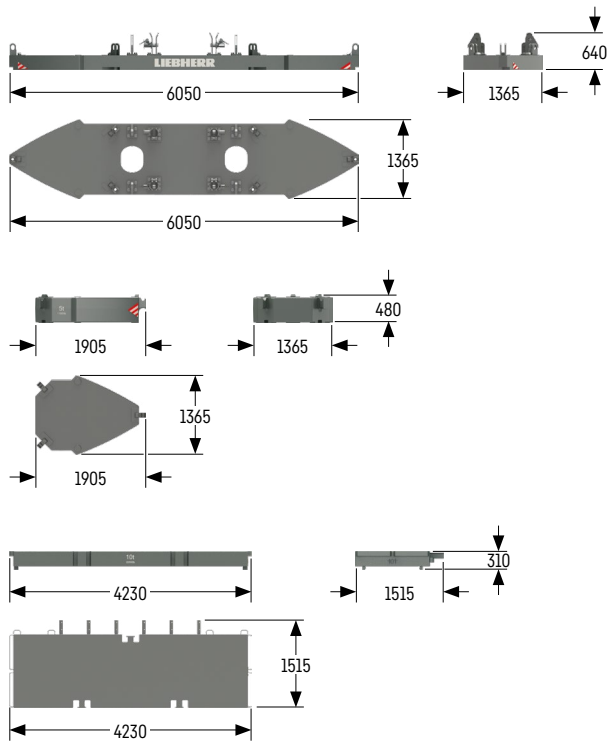

Basic counterweight slab without tie-down (1x)

Weight	kg 12000
--------	----------

Counterweight slab (8x)

Weight	kg 5000
--------	---------

Carbody counterweight (2x)

Weight	kg 10000
--------	----------

Pulley block with additional weights / load hooks

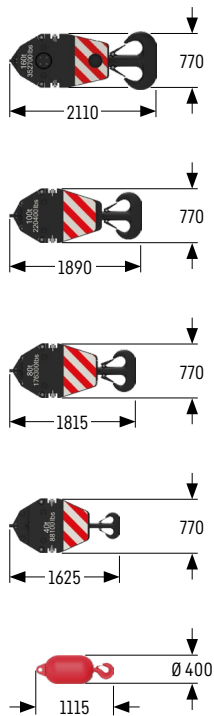

160 t pulley block - 7 pulleys

Width	mm 885
Weight	kg 1500 / 2250 / 3000

100 t pulley block - 5 pulleys

Width	mm 745
Weight	kg 1300 / 1800 / 2300

80 t pulley block - 3 pulleys

Width	mm 565
Weight	kg 1000 / 1500 / 2000

40 t pulley block - 1 pulley

Width	mm 490
Weight	kg 700 / 1100 / 1500

12.5 t load hook

Weight	kg 600
--------	--------

Self-assembly system

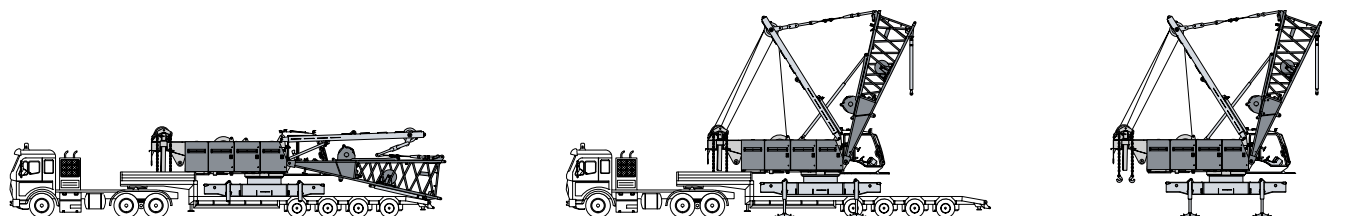

Unloading of basic machine

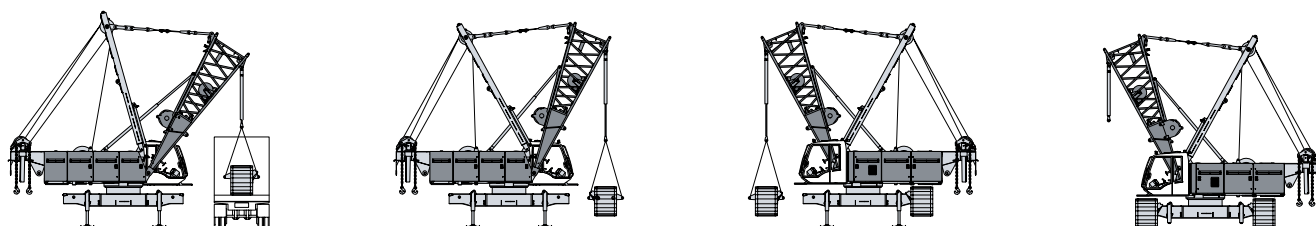

Unloading and assembly of crawler side frames

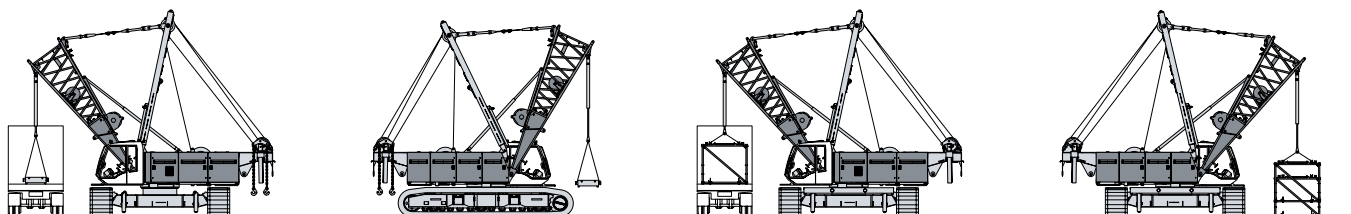

Unloading and assembly of carbody counterweight

Unloading and assembly of boom

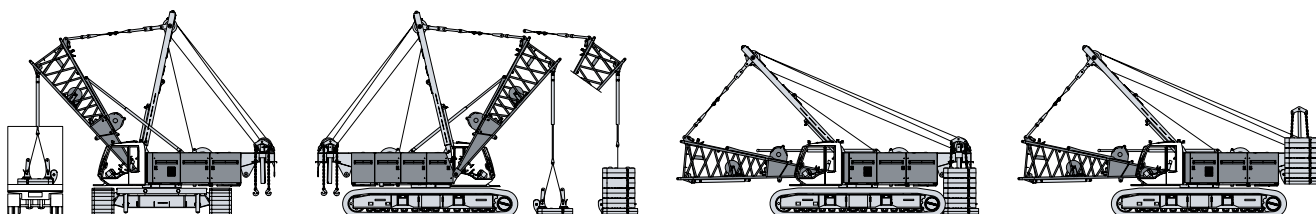

Unloading and assembly of rear counterweight



Assembly of boom

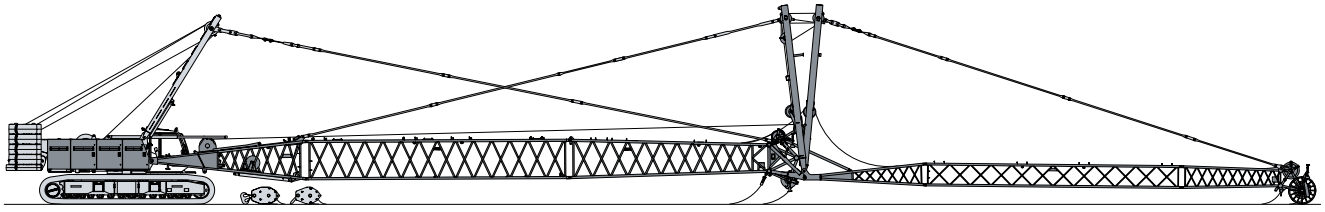

Reeving of hoist and luffing jib ropes

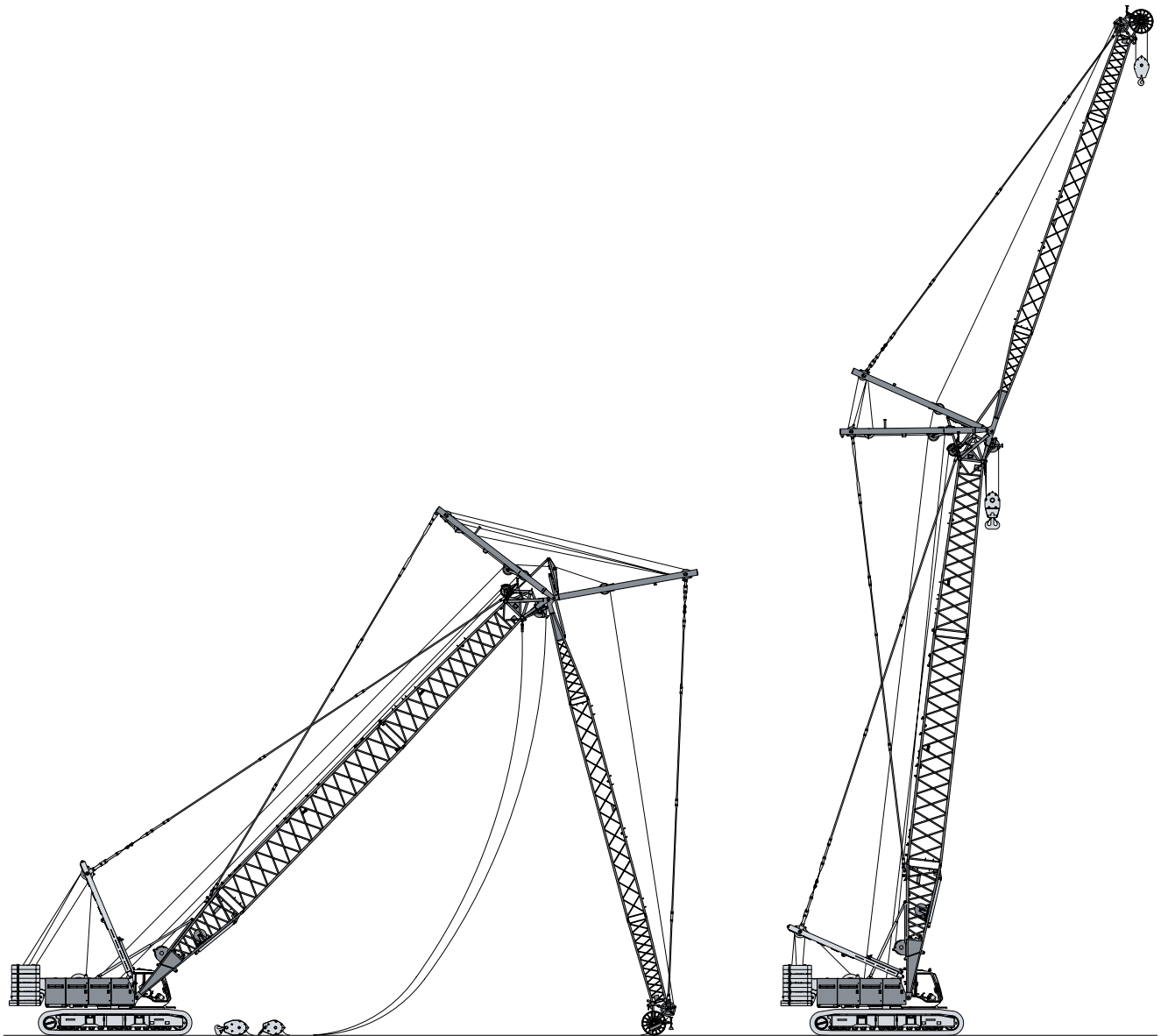

Erecting of main boom and luffing jib

Boom combinations

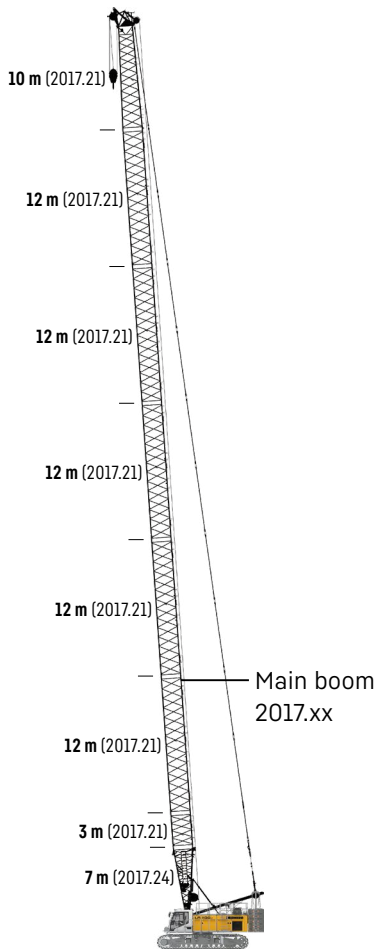

Main boom

Mode 1

Max. length

2017.xx m 80

Further information on page 16.

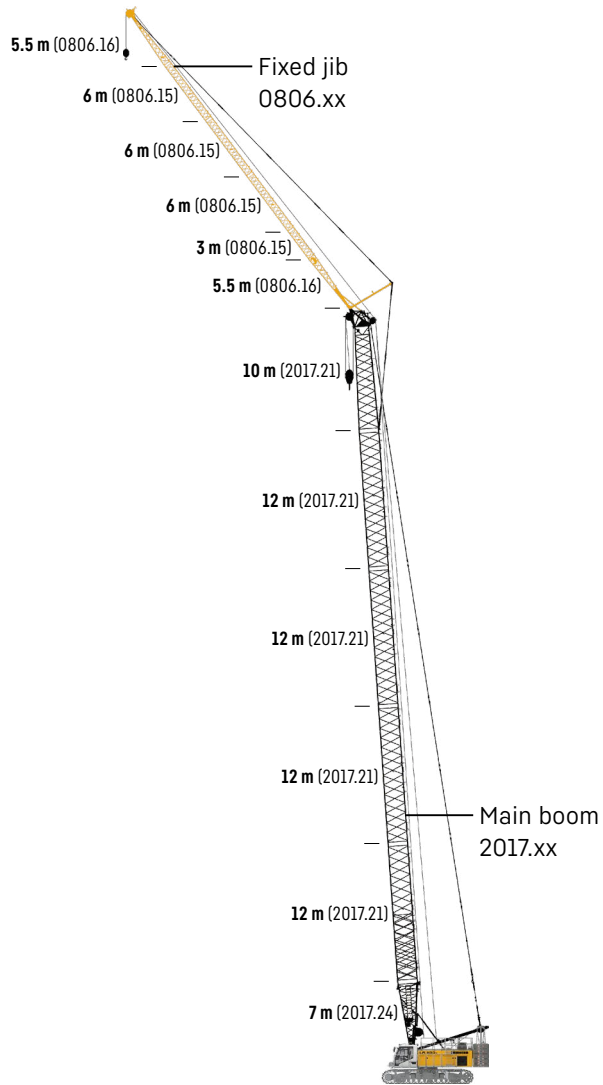

Main boom + fixed jib

Mode 3

Max. combination

2017.xx m 65 68

0806.xx m 32 23

Total length m 97 91

Further information on page 24.

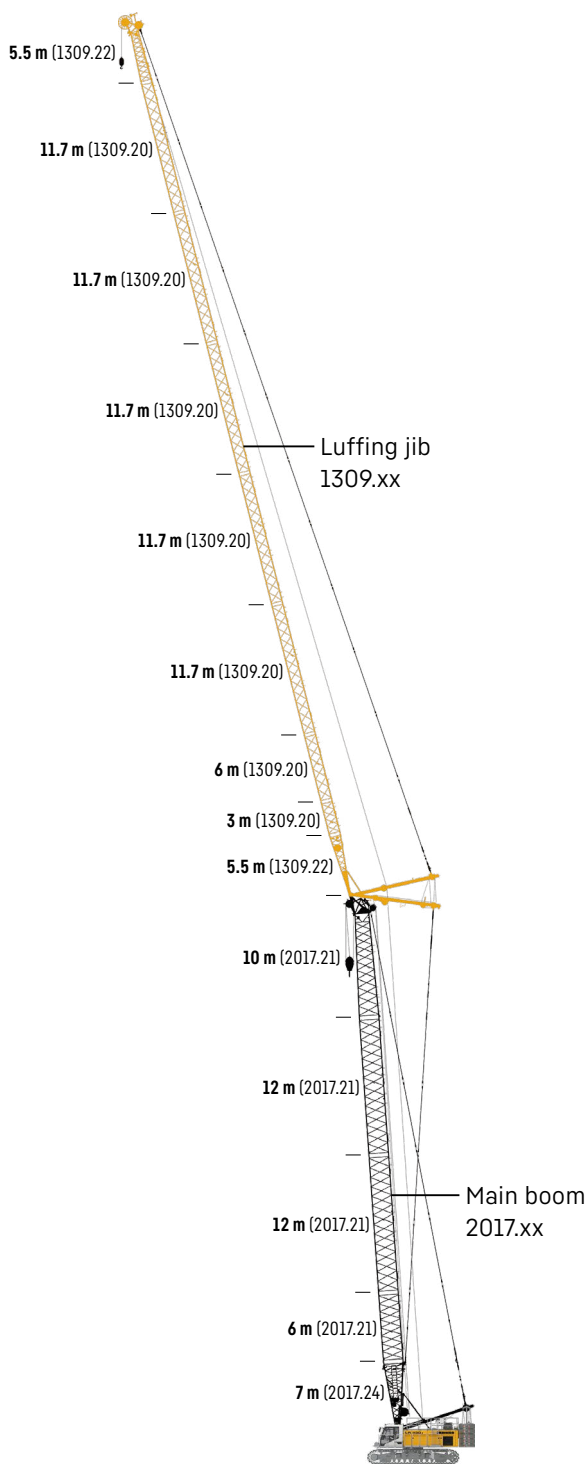

Main boom + luffing jib

Mode 4

Max. combination

2017.xx	m	47	53
1309.xx	m	78.5	49.1
Total length	m	125.5	102.1

Further information on page 18.

Main boom 2017.xx

Main boom lengths 17-80 m

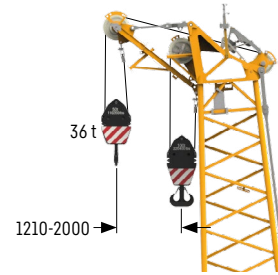
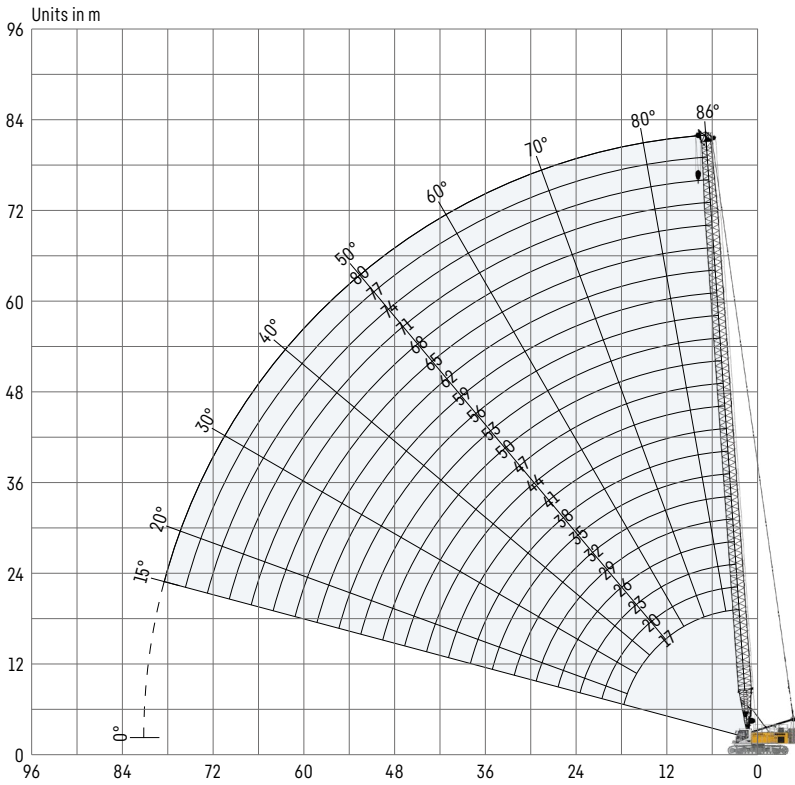

Auxiliary jib 36 t (option)

The maximum capacity of the auxiliary jib is 36 t. The corresponding load chart is programmed in the LML system.

Main boom configuration 2017.xx

Boom section	Amount of boom sections											
	1	1	1	1	1	1	1	1	1	1	1	
Boom foot 7 m	1				1				1			1
Boom section 3 m		1			1			1			1	
Boom section 6 m			1		1			1		1		1
Boom section 12 m					1	1	1	1	2	2	2	2
Boom head 10 m	1	1	1	1	1	1	1	1	1	1	1	1
Boom length [m]	17	20	23	26	29	32	35	38	41	44	47	
Auxiliary jib	✓	✓	✓	✓	✓	✓	✓	✓	✓	✓	✓	✓
Boom foot 7 m	1	1	1	1	1	1	1	1	1	1	1	1
Boom section 3 m	1		1		1		1		1		1	
Boom section 6 m	1			1	1			1	1			1
Boom section 12 m	2	3	3	3	3	4	4	4	4	5	5	5
Boom head 10 m	1	1	1	1	1	1	1	1	1	1	1	1
Boom length [m]	50	53	56	59	62	65	68	71	74	77	80	
Auxiliary jib	✓	✓	✓	✓	✓	✓	✓	✓	✓	✓	✓	✓

Load capacities with main boom

Load capacities in [t] with 52.3 t rear counterweight and 20 t carbody counterweight

	Boom length [m]												
	17	20	26	32	38	44	50	56	62	68	71	77	80
3.6		137.2											
4	137.2	137.2											
5	116.9	114.2	108.2	97.3	79.9								
6	98.6	97.4	92.5	88.0	75.0	62.0	52.7						
7	85.7	83.6	81.2	76.5	69.2	56.9	50.3	44.9	36.7	29.1			
8	75.0	74.2	71.2	68.4	62.5	53.0	47.5	42.9	35.6	28.9	26.5	21.8	18.9
9	66.8	66.0	63.6	61.3	57.6	49.1	44.7	41.5	34.3	27.7	25.5	21.4	18.8
10	60.5	59.5	57.8	55.3	52.8	46.2	42.0	39.5	33.2	26.7	24.6	20.6	18.0
11	54.8	54.5	52.6	50.6	48.1	43.3	40.0	37.8	31.8	25.8	23.8	20.0	17.4
12	50.3	49.9	48.1	46.7	44.2	40.2	37.9	36.4	30.6	24.7	22.9	19.4	16.9
13	45.7	45.7	44.6	43.0	41.1	37.5	35.2	35.1	29.6	23.8	22.0	18.7	16.2
14	41.3	41.3	41.3	39.8	38.3	35.2	32.9	32.6	28.8	23.1	21.3	18.1	15.6
16	34.4	34.5	34.5	34.4	33.4	31.4	29.1	28.4	25.7	21.6	20.1	17.2	14.7
18	12.1	29.4	29.4	29.3	29.1	27.9	26.2	25.3	23.2	19.9	18.6	16.2	13.8
20		25.5	25.5	25.5	25.3	25.1	23.6	22.8	21.2	18.6	17.4	15.2	12.9
22			22.5	22.4	22.2	22.0	21.5	20.5	19.3	17.5	16.4	14.3	12.0
24			19.9	19.9	19.7	19.5	19.2	18.7	17.6	16.1	15.4	13.6	11.4
26			17.8	17.8	17.6	17.4	17.1	16.9	16.1	14.8	14.2	12.8	10.8
28				16.1	15.9	15.7	15.4	15.1	14.8	13.6	13.1	11.9	10.2
30				14.5	14.4	14.2	13.9	13.6	13.3	12.6	12.2	11.1	9.6
32				13.2	13.1	12.9	12.6	12.4	12.1	11.8	11.4	10.4	9.1
34					12.0	11.8	11.5	11.3	10.9	10.6	10.5	9.8	8.7
36					11.0	10.8	10.5	10.3	10.0	9.7	9.5	9.1	8.3
38					10.0	9.9	9.6	9.4	9.1	8.8	8.6	8.3	7.8
40						9.1	8.8	8.6	8.3	8.0	7.8	7.5	7.2
42						8.4	8.1	7.9	7.6	7.3	7.1	6.8	6.6
44						7.7	7.5	7.2	7.0	6.7	6.5	6.2	6.0
46							6.9	6.7	6.4	6.1	5.9	5.6	5.4
48							6.3	6.1	5.8	5.6	5.4	5.1	4.9
50							5.8	5.6	5.3	5.1	4.9	4.6	4.4
55								4.5	4.3	4.0	3.9	3.6	3.4
60									3.4	3.1	3.0	2.7	2.5
65										2.3	2.2		

TLT 11962137. Above load charts are for reference only. For actual lift duty please refer to load chart in operator's cabin or manual. Otherwise we recommend you to plan your lifting job using Crane Planner 2.0.



www.liebherr.com/CranePlanner

 **Crane Planner 2.0**

Luffing jib 1309.xx

Jib lengths 22.7-78.5 m

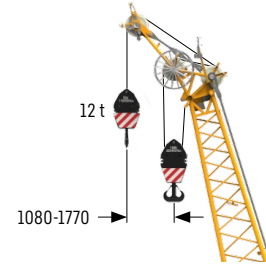
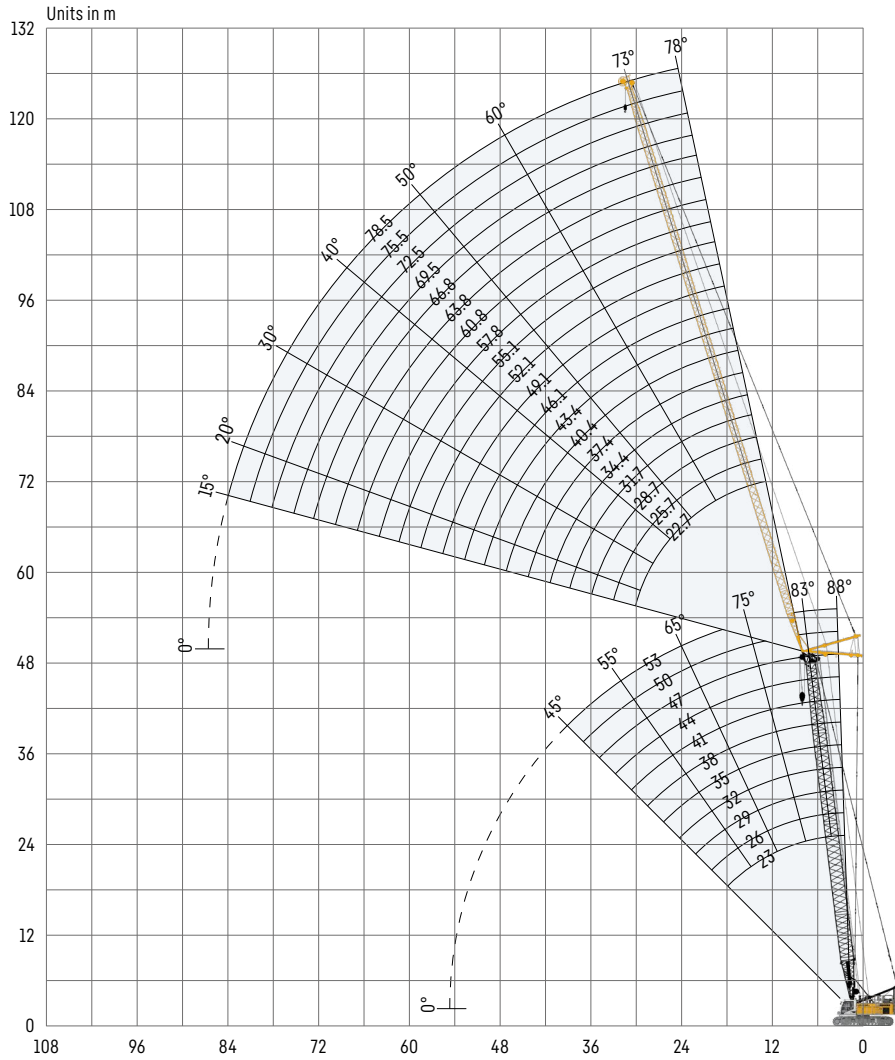

Auxiliary jib 12 t (option)
The maximum capacity of the auxiliary jib is 12 t.

Jib configuration 1309.xx

Jib section	Amount of jib sections																			
	1	1	1	1	1	1	1	1	1	1	1	1	1	1	1	1	1	1	1	1
Jib foot 5.5 m	1	1	1	1	1	1	1	1	1	1	1	1	1	1	1	1	1	1	1	1
Jib section 3 m		1		1		1		1		1		1		1		1		1		1
Jib section 6 m			1	1			1	1			1	1			1	1			1	1
Jib section 11.7 m	1	1	1	1	2	2	2	2	3	3	3	3	4	4	4	4	5	5	5	5
Jib head 5.5 m	1	1	1	1	1	1	1	1	1	1	1	1	1	1	1	1	1	1	1	1
Jib length [m]	22.7	25.7	28.7	31.7	34.4	37.4	40.4	43.4	46.1	49.1	52.1	55.1	57.8	60.8	63.8	66.8	69.5	72.5	75.5	78.5
Auxiliary jib	✓	✓	✓	✓	✓	✓	✓	✓	✓	✓	✓	✓	✓	✓	✓	✓	✓	✓	✓	✓

For main boom configuration please refer to the table on page 16.

Load capacities with luffing jib

Load capacities in [t] with 23 m main boom 88°

Radius [m]	Jib length [m]					
	22.7	34.4	46.1	57.8	69.5	78.5
8.2	43.3					
10	38.5					
13	30.9	25.0				
14	29.2	23.5	15.5			
16	25.6	21.3	14.7	9.5		
20	20.6	17.5	13.4	8.8	5.6	3.6
24	17.2	14.7	11.7	8.1	5.2	3.3
28		12.8	10.6	7.7	4.9	3.0
42			7.4	6.3	4.2	2.4
50				5.3	3.8	2.1
55				4.6	3.6	2.0
70					2.3	

52.3 t rear counterweight and 20 t carbody counterweight

Load capacities in [t] with 38 m main boom 88°

Radius [m]	Jib length [m]					
	22.7	34.4	46.1	57.8	69.5	78.5
8.8	31.5					
12	26.5	20.5				
13	24.8	19.6				
18	19.0	15.7	11.8	8.1		
20	17.0	14.6	11.2	7.8	5.2	
24	14.0	12.3	9.9	7.3	4.8	3.1
28		10.6	8.9	6.8	4.6	2.8
30		9.9	8.4	6.7	4.4	2.7
36		8.3	7.1	5.9	4.1	2.5
42			5.9	5.2	3.8	2.3
50				4.0	3.3	2.0
60					2.3	

52.3 t rear counterweight and 20 t carbody counterweight

Load capacities in [t] with 44 m main boom 88°

Radius [m]	Jib length [m]					
	22.7	34.4	46.1	57.8	69.5	78.5
9	27.0					
12	23.0	17.9				
14	20.3	16.4	11.8			
20	15.0	12.3	9.9	7.3	4.9	
22	13.8	11.3	9.3	6.9	4.7	3.1
26	10.5	9.9	8.3	6.4	4.4	2.8
36		7.5	6.4	5.2	3.8	2.4
42			5.5	4.6	3.4	2.2
46			5.0	4.1	3.1	2.1
48			4.7	3.8	3.0	
55				3.2	2.4	
60				2.6		

52.3 t rear counterweight and 20 t carbody counterweight

Load capacities in [t] with 50 m main boom 88°

Radius [m]	Jib length [m]					
	22.7	34.4	49.1	57.8	63.8	69.5
9.2	22.8					
12	19.6	15.3				
16	15.9	12.7	9.2			
18	14.4	11.5	8.7	7.0	5.7	
20	13.3	10.6	8.0	6.6	5.5	4.6
22	12.4	9.8	7.5	6.2	5.3	4.4
26	8.9	8.6	6.7	5.6	4.8	4.0
32		7.6	5.8	5.0	4.2	3.6
44			4.4	3.8	3.3	2.7
50			3.9	3.2	2.7	2.4
55				2.8	2.3	
60				2.4	2.0	

52.3 t rear counterweight and 20 t carbody counterweight

Load capacities in [t] with 53 m main boom 88°

Radius [m]	Jib length [m]					
	22.7	28.7	34.4	37.4	43.4	49.1
9.3	20.8					
11	19.2	16.9				
12	18.1	15.9	14.0			
14	16.2	14.3	12.8	12.0	10.4	
16	14.7	12.9	11.7	10.9	9.7	8.5
22	11.4	9.8	9.1	8.6	7.8	7.0
26	10.1	8.8	8.0	7.6	6.9	6.2
30		8.0	7.3	6.9	6.2	5.6
34			6.8	6.4	5.7	5.1
40				4.8	5.1	4.5
46					3.8	4.0
50						3.6

52.3 t rear counterweight and 20 t carbody counterweight

TLT 11962137. Above load charts are for reference only. For actual lift duty please refer to load chart in operator's cabin or manual. Otherwise we recommend you to plan your lifting job using Crane Planner 2.0.



www.liebherr.com/CranePlanner

Crane Planner 2.0

Load capacities with luffing jib

Load capacities in [t] with 23 m main boom 83°

Radius [m]	Jib length [m]					
	22.7	34.4	46.1	57.8	69.5	78.5
12.2	37.6					
16	29.1	24.0				
20	22.9	19.8	13.8			
24	18.7	16.5	12.7	8.3		
26	17.4	15.2	12.3	8.1	5.1	
28		14.2	11.8	7.9	5.0	
32		12.5	10.6	7.6	4.8	2.9
38		10.9	9.2	7.1	4.5	2.6
42			8.4	6.9	4.3	2.4
50			6.6	5.9	3.9	2.2
55				5.4	3.7	2.1
70					3.1	

52.3 t rear counterweight and 20 t carbody counterweight

Load capacities in [t] with 38 m main boom 83°

Radius [m]	Jib length [m]					
	22.7	34.4	46.1	57.8	69.5	78.5
14	24.9					
18	20.2	16.8				
24	15.2	13.1	10.4			
26	14.2	12.2	9.8	7.3		
28	13.4	11.5	9.3	7.1	4.7	
30		11.0	9.0	6.9	4.6	
32		10.4	8.5	6.6	4.5	2.8
40		8.6	7.1	5.7	4.1	2.4
48			6.0	4.9	3.5	2.1
50			5.7	4.7	3.5	2.1
60				3.8	2.9	
70					2.2	

52.3 t rear counterweight and 20 t carbody counterweight

Load capacities in [t] with 44 m main boom 83°

Radius [m]	Jib length [m]					
	22.7	34.4	46.1	57.8	69.5	78.5
14.8	20.1					
16	19.0					
20	15.4	12.7				
22	14.0	11.6	9.4			
26	12.2	9.9	8.3	6.5		
28	11.6	9.3	7.9	6.2		
30		8.9	7.6	6.0	4.3	
32		8.5	7.2	5.7	4.1	2.7
40		7.1	6.0	4.8	3.5	2.4
46			5.3	4.2	3.1	2.2
55				3.5	2.5	
60				3.1	2.2	

52.3 t rear counterweight and 20 t carbody counterweight

Load capacities in [t] with 50 m main boom 83°

Radius [m]	Jib length [m]					
	22.7	34.4	49.1	57.8	66.8	69.5
15.5	16.4					
20	13.3	10.7				
22	12.0	9.8				
24	11.3	9.0	7.0			
26	10.7	8.5	6.6	5.4		
28	10.2	7.9	6.2	5.2		
30	9.6	7.6	5.9	5.0	3.9	3.6
38		6.5	4.9	4.1	3.2	3.0
44			4.3	3.5	2.7	2.5
50			3.9	3.1	2.3	2.1
55			3.5	2.8	2.1	
60				2.5		

52.3 t rear counterweight and 20 t carbody counterweight

Load capacities in [t] with 53 m main boom 83°

Radius [m]	Jib length [m]					
	22.7	28.7	34.4	37.4	43.4	49.1
15.9	14.8					
18	13.5	11.8				
20	12.2	10.7	9.8			
22	11.1	9.7	9.0	8.5	7.5	
24	10.4	9.0	8.2	7.8	7.1	6.3
26	9.8	8.4	7.7	7.3	6.7	6.0
30	8.9	7.7	6.9	6.5	6.0	5.3
32		7.4	6.6	6.2	5.6	5.1
38			5.9	5.6	4.9	4.4
44				4.9	4.5	3.9
50					3.9	3.5
55						3.1

52.3 t rear counterweight and 20 t carbody counterweight

TLT 11962137. Above load charts are for reference only. For actual lift duty please refer to load chart in operator's cabin or manual. Otherwise we recommend you to plan your lifting job using Crane Planner 2.0.



www.liebherr.com/CranePlanner

Crane Planner 2.0

Load capacities with luffing jib

Load capacities in [t] with 23 m main boom 75°

Radius [m]	Jib length [m]					
	22.7	34.4	46.1	57.8	69.5	78.5
18.3	27.9					
20	26.0					
24	21.0	19.7				
30	15.9	15.3	12.1			
34		13.3	11.4	7.6		
36		12.4	10.9	7.4		
40		10.8	10.0	7.2	4.5	
42			9.4	7.0	4.4	2.5
46			8.6	6.8	4.2	2.4
55				6.0	3.8	2.1
60				5.3	3.6	
75					3.1	

52.3 t rear counterweight and 20 t carbody counterweight

Load capacities in [t] with 38 m main boom 75°

Radius [m]	Jib length [m]					
	22.7	34.4	46.1	57.8	69.5	78.5
22.2	17.4					
28	14.0	12.4				
30	13.1	11.7				
34	12.0	10.5	8.7			
38		9.5	7.9	6.2		
40		9.0	7.6	6.1		
42		8.7	7.3	5.9	3.9	
46			6.6	5.5	3.8	2.3
50			6.1	5.1	3.7	2.2
55			5.6	4.6	3.4	2.1
60				4.2	3.1	
75					2.3	

52.3 t rear counterweight and 20 t carbody counterweight

Load capacities in [t] with 44 m main boom 75°

Radius [m]	Jib length [m]					
	22.7	34.4	49.1	60.8	66.8	75.5
23.7	13.2					
26	12.6					
28	11.7					
30	11.0	9.3				
36	8.8	7.9	6.5			
40		7.1	5.9	4.5		
42		6.8	5.6	4.4		
44		6.5	5.3	4.3	3.6	
46		6.3	5.1	4.1	3.5	2.4
60			3.8	2.9	2.5	
65				2.6	2.2	
70				2.3		

52.3 t rear counterweight and 20 t carbody counterweight

Load capacities in [t] with 50 m main boom 75°

Radius [m]	Jib length [m]					
	22.7	34.4	49.1	52.1	60.8	66.8
25.3	10.3					
30	9.0					
32	8.5	6.9				
34	8.0	6.5				
38		5.9	4.7	4.4		
42		5.3	4.2	4.0	3.2	
44		5.1	4.0	3.8	3.1	2.5
46		5.0	3.8	3.6	2.9	2.5
50			3.4	3.3	2.6	2.2
55			3.0	2.9	2.2	
60			2.8	2.6		
65				2.4		

52.3 t rear counterweight and 20 t carbody counterweight

Load capacities in [t] with 53 m main boom 75°

Radius [m]	Jib length [m]					
	22.7	28.7	37.4	40.4	46.1	49.1
26.1	9.0					
30	8.0	7.0				
32	7.5	6.6				
34	7.1	6.2	5.5	5.1		
36	6.9	5.9	5.1	4.9	4.4	
38	6.7	5.6	4.8	4.6	4.2	3.9
40		5.4	4.6	4.4	4.0	3.7
42		5.2	4.4	4.2	3.8	3.5
46			4.0	3.8	3.4	3.1
48			3.9	3.6	3.2	3.0
55				2.9	2.8	2.5
60					2.6	2.3

52.3 t rear counterweight and 20 t carbody counterweight

TLT 11962137. Above load charts are for reference only. For actual lift duty please refer to load chart in operator's cabin or manual. Otherwise we recommend you to plan your lifting job using Crane Planner 2.0.



www.liebherr.com/CranePlanner

Crane Planner 2.0

Load capacities with luffing jib

Load capacities in [t] with 23 m main boom 65°

Radius [m]	Jib length [m]					
	22.7	34.4	46.1	57.8	69.5	75.5
25.4	18.3					
26	17.9					
30	15.0					
34	12.8	12.4				
36		11.5				
38		10.8				
40		10.1	9.6			
46			7.9	6.8		
55			6.1	5.7	3.9	
60				4.9	3.8	2.6
70					3.3	2.4
80						2.1

52.3 t rear counterweight and 20 t carbody counterweight

Load capacities in [t] with 35 m main boom 65°

Radius [m]	Jib length [m]					
	22.7	31.7	34.4	49.1	60.8	69.5
30.5	13.2					
36	10.7	10.3				
38	10.0	9.6	9.5			
42		8.4	8.4			
44		7.9	7.8			
48		7.0	7.0	6.3		
50			6.5	5.9		
55				5.1	4.5	
60				4.4	3.9	3.4
65				3.9	3.4	2.9
70					2.9	2.5
75					2.5	2.1

52.3 t rear counterweight and 20 t carbody counterweight

Load capacities in [t] with 41 m main boom 65°

Radius [m]	Jib length [m]					
	22.7	34.4	46.1	52.1	57.8	66.8
33	11.2					
34	10.8					
40	8.8	8.2				
42	8.2	7.7				
44		7.2				
48		6.4	5.8			
50		6.0	5.5	5.1		
55			4.8	4.4	4.0	
60			4.1	3.8	3.5	2.9
65				3.3	3.0	2.5
70				2.9	2.6	2.1
75					2.3	

52.3 t rear counterweight and 20 t carbody counterweight

Load capacities in [t] with 47 m main boom 65°

Radius [m]	Jib length [m]					
	22.7	28.7	37.4	46.1	49.1	57.8
35.6	9.3					
38	8.6					
40	8.1	7.7				
42	7.6	7.2				
44	7.1	6.8	6.2			
46		6.4	5.8			
48		6.0	5.5			
50		5.7	5.2	4.7		
55			4.6	4.0	3.8	
60				3.5	3.3	2.8
65				3.1	2.9	2.4
70					2.5	2.0

52.3 t rear counterweight and 20 t carbody counterweight

Load capacities in [t] with 50 m main boom 65°

Radius [m]	Jib length [m]					
	22.7	31.7	37.4	49.1	52.1	55.1
36.8	8.3					
38	8.1					
40	7.6					
42	7.2	6.5				
44	6.8	6.1				
46		5.8	5.4			
48		5.5	5.1			
50		5.2	4.8			
55			4.2	3.4	3.2	
60			3.7	2.9	2.8	2.6
65				2.5	2.4	2.2
70				2.2	2.0	

52.3 t rear counterweight and 20 t carbody counterweight

TLT 11962137. Above load charts are for reference only. For actual lift duty please refer to load chart in operator's cabin or manual. Otherwise we recommend you to plan your lifting job using Crane Planner 2.0.



www.liebherr.com/CranePlanner

Crane Planner 2.0

Fixed jib 0806.xx

Jib lengths 11-32 m

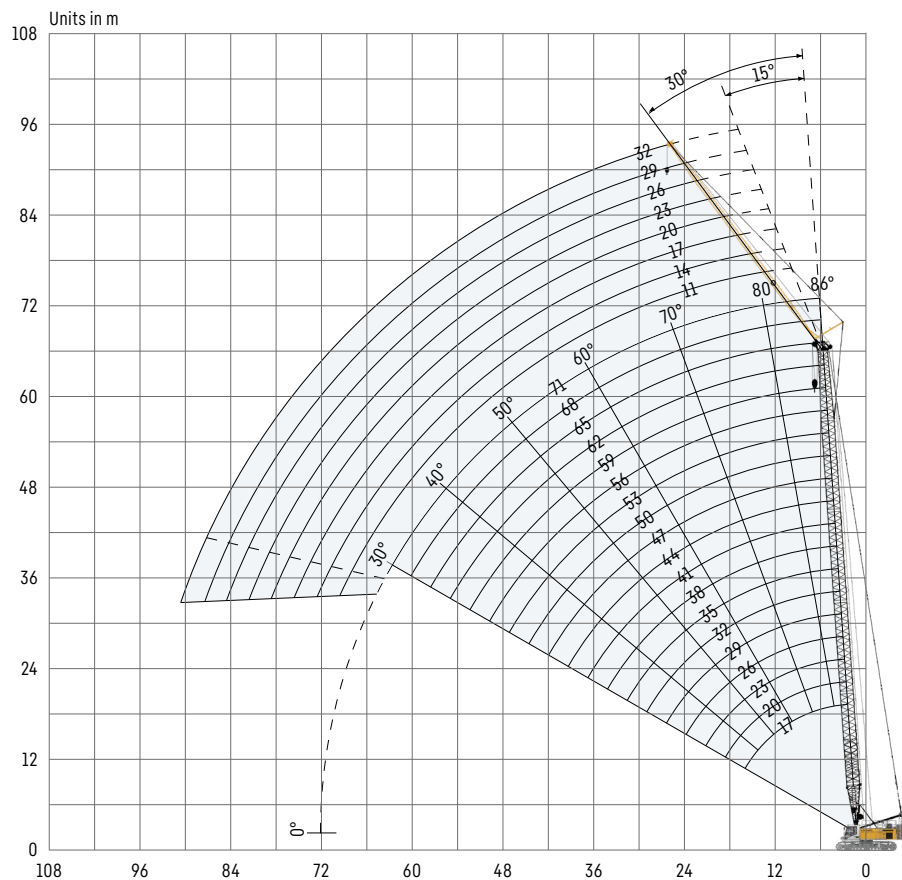

Jib configuration 0806.xx

Jib section	Amount of jib sections							
Jib foot 5.5 m	1	1	1	1	1	1	1	1
Jib section 3 m		1		1		1		1
Jib section 6 m			1	1	2	2	3	3
Jib head 5.5 m	1	1	1	1	1	1	1	1
Jib length [m]	11	14	17	20	23	26	29	32

For main boom configuration please refer to the table on page 16.

Load capacities with fixed jib 15°

Load capacities in [t] with 26 m main boom

Radius [m]	Jib length [m]			
	11	20	26	32
5.8	23.4			
10	22.2	10.8		
12	21.6	10.4	7.5	
16	19.3	9.7	7.0	5.1
18	18.2	9.4	6.7	4.9
20	17.1	9.1	6.5	4.7
24	15.1	8.6	6.1	4.4
26	13.9	8.3	6.0	4.2
36		7.2	5.3	3.7
42		6.7	5.1	3.4
50			4.9	3.2
55				3.1

52.3 t rear counterweight and 20 t carbody counterweight

Load capacities in [t] with 35 m main boom

Radius [m]	Jib length [m]			
	11	20	26	32
6.1	22.6			
10	21.9	11.0		
12	21.0	10.5		
18	17.8	9.6	6.8	4.9
20	17.0	9.4	6.6	4.8
24	15.1	8.9	6.3	4.5
32	12.4	7.9	5.8	4.0
40	9.5	6.9	5.3	3.7
42	8.7	6.7	5.2	3.6
50		6.2	4.7	3.3
55			4.5	3.2
60				3.2

52.3 t rear counterweight and 20 t carbody counterweight

Load capacities in [t] with 44 m main boom

Radius [m]	Jib length [m]			
	11	20	26	32
6.4	21.1			
10	19.2			
13	17.3	10.3	7.1	
16	15.4	9.9	6.9	4.9
24	11.6	9.0	6.2	4.5
32	9.0	8.3	5.8	4.0
40	7.5	7.5	5.4	3.7
42	7.2	7.2	5.3	3.7
50	4.6	6.3	4.9	3.4
55		4.9	4.6	3.3
60		3.8	4.0	3.2
65			3.3	3.0

52.3 t rear counterweight and 20 t carbody counterweight

Load capacities in [t] with 59 m main boom

Radius [m]	Jib length [m]			
	11	20	26	32
6.9	16.3			
10	15.6			
14	13.6	9.0	5.9	
16	13.0	8.9	5.8	4.1
18	12.6	8.8	5.7	4.1
24	11.1	8.6	5.5	4.0
32	8.3	7.7	5.3	3.8
40	5.0	5.9	5.1	3.6
50	2.9	3.8	4.3	3.4
55	2.0	2.9	3.6	3.3
60		2.2	2.8	2.8
65			2.1	2.2

52.3 t rear counterweight and 20 t carbody counterweight

Load capacities in [t] with 68 m main boom

Radius [m]	Jib length [m]			
	11	14	17	23
7.3	13.6			
11	12.6	11.3	8.9	
14	11.5	10.8	8.8	6.1
16	10.8	10.5	8.7	6.1
18	10.2	10.0	8.6	6.0
24	8.6	8.6	8.4	5.9
32	6.7	7.0	7.0	5.8
36	4.9	5.8	6.4	5.7
40	3.5	4.2	4.8	5.6
46	2.0	2.4	2.9	3.6
48			2.4	3.1
50				2.6

52.3 t rear counterweight and 20 t carbody counterweight

TLT 11962137. Above load charts are for reference only. For actual lift duty please refer to load chart in operator's cabin or manual. Otherwise we recommend you to plan your lifting job using Crane Planner 2.0.



www.liebherr.com/CranePlanner

Crane Planner 2.0

Load capacities with fixed jib 30°

Load capacities in [t] with 26 m main boom

Radius [m]	Jib length [m]			
	11	20	26	32
8.3	20.2			
14	17.3	8.8		
18	15.6	8.4	6.2	
22	14.3	7.9	5.9	4.1
24	13.7	7.8	5.8	4.0
28	12.0	7.6	5.6	3.8
32	11.1	7.2	5.4	3.6
36	10.6	6.8	5.2	3.5
40		6.5	5.1	3.3
42		6.5	5.0	3.3
48			4.9	3.2
50			4.9	3.2

52.3 t rear counterweight and 20 t carbody counterweight

Load capacities in [t] with 35 m main boom

Radius [m]	Jib length [m]			
	11	20	26	32
8.6	18.6			
13	16.6			
18	14.8	8.5	6.2	
22	13.7	8.1	6.0	4.2
26	12.8	7.7	5.7	4.0
30	12.0	7.4	5.6	3.8
34	10.9	7.1	5.4	3.7
38	9.9	6.8	5.3	3.5
42	8.5	6.3	5.1	3.4
50		5.8	4.5	3.3
55			4.4	3.2
60				3.2

52.3 t rear counterweight and 20 t carbody counterweight

Load capacities in [t] with 44 m main boom

Radius [m]	Jib length [m]			
	11	20	26	32
8.9	17.2			
14	15.6			
20	13.8	8.2	6.0	
24	12.3	7.9	5.8	4.0
28	10.8	7.6	5.6	3.8
32	9.4	7.2	5.5	3.7
36	8.4	6.9	5.3	3.6
44	6.6	6.3	5.0	3.4
50	4.6	5.7	4.6	3.3
55		4.9	4.3	3.3
60		3.8	3.9	3.2
65			3.4	3.1

52.3 t rear counterweight and 20 t carbody counterweight

Load capacities in [t] with 59 m main boom

Radius [m]	Jib length [m]			
	11	20	26	32
9.5	15.0			
16	13.3	8.2		
18	12.7	7.9		
24	11.1	7.2	5.4	3.8
28	10.1	6.8	5.2	3.7
32	8.9	6.5	5.0	3.6
44	4.3	5.1	4.4	3.4
50	3.1	4.3	4.1	3.3
55	2.2	3.4	3.9	3.1
60		2.6	3.1	3.0
65			2.3	2.5
70				2.1

52.3 t rear counterweight and 20 t carbody counterweight

Load capacities in [t] with 68 m main boom

Radius [m]	Jib length [m]			
	11	14	20	23
9.8	12.9			
12	12.5	10.9		
14	11.9	10.7		
18	10.7	10.0	7.4	6.0
26	8.3	8.5	6.7	5.9
32	6.7	7.1	6.2	5.5
34	6.4	6.7	6.0	5.4
40	3.9	4.9	5.5	4.9
46	2.2	2.8	3.9	4.2
48		2.3	3.3	3.6
50			2.8	3.1
55				2.0

52.3 t rear counterweight and 20 t carbody counterweight

TLT 11962137. Above load charts are for reference only. For actual lift duty please refer to load chart in operator's cabin or manual. Otherwise we recommend you to plan your lifting job using Crane Planner 2.0.



www.liebherr.com/CranePlanner

Crane Planner 2.0



Download datasheet



Please contact us.

Liebherr-Werk Nenzing GmbH · Dr. Hans Liebherr Str. 1 · 6710 Nenzing, Austria
Phone +43 50809 41-473 · crawler.crane@liebherr.com · www.liebherr.com
facebook.com/LiebherrConstruction