

---

# ECBNh 9972

---

Integrated fridge-freezer with  
BioFresh and NoFrost

# LIEBHERR

Fully Integrated



The more stars the more energy efficient

**ENERGY RATING**

Energy consumption  
**353**  
kWh per year

The model is a combination unit (REF121 BC 2003).  
According to the standards EN 60051 and EN 60052.

Compare models at [www.energyrating.gov.au](http://www.energyrating.gov.au)

Fully Integrated

**LIEBHERR**

# ECBNh 9972

Integrated fridge-freezer with BioFresh and NoFrost

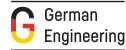

← 91 → 203



Bio Fresh Plus	No Frost	Duo Cooling	Infinity Swipe	Infinity Light	Super Cool	Super Frost	Infinity Spring	Ice Maker	Soft System
Active Green	Soft-Telescopic Rails								

Type	Fixed door / Built-in appliance for integrated use
Energy consumption (kWh/yr) / Star rating	353 / 4.5
Total volume	511 l <sup>1</sup>
Volume	BioFresh compartment: 86.8 l / Freezer compartment: 184 l
Climate rating	SN-T (+10 °C to +43 °C)
Frequency / voltage	50/60 Hz / 220-240 V~
Connection Rating	3.0 A 248.5 W
Aperture dimensions in cm (h / w / d)	213.4 / 91.4 / min. 63.5
<b>Controls</b>	
Type of Control	3.5" LCD colour display, behind the door, touch- & swipe Digital temperature display for fridge, BioFresh and freezer compartments
Door alarm	acoustic
Alarm in case of malfunction	visual and acoustic
<b>Fridge compartment</b>	
Forced air system	PowerCooling with FreshAir activated charcoal filter
Door interior	Comfort GlassLine storage shelves with bottle holder
Bottle shelf	Integrated bottle shelf
Interior light	InfinityLight LED BioFresh lighting
BioFresh-Safes	1 BioFresh safe with SoftTelescopic
<b>Freezer compartment</b>	
Interior light	LED lighting
Number of drawers	2 drawers with SoftTelescopic
IceMaker	with fixed 3/4" water connection, LED lighting
Ice cube capacity in 24 hours	1.4 kg
Ice cube stock	3.0 kg
Freezing capacity in 24 hours	12 kg
Temperature rise time	21 h
<b>Features</b>	
Door hinges	Door hinge left fixed/right fixed
Replaceable door seal	yes
EAN-Nr.	9005382276556

<sup>1</sup> In accordance with Regulation EU 2019/2016 we indicate the total volume to the nearest integer (rounded off) and the volume of the frozen compartments and refrigeration compartments to one place after the decimal point.

## Features

---



### German Engineering

Our superior products offer premium quality, cutting edge design, and innovative features that best fit your lifestyle. The use of high quality materials, perfectly detailed finishes, and elite cooling components are combined with the latest production processes, resulting in an outstanding cooling product.



### BioFresh-Plus

The BioFresh Plus Safe guarantees you a perfect storage climate and extra-long freshness of fruit and vegetables, meat and dairy products as well as fish and seafood – all in just one compartment. Depending on the food, the Meat & Dairy safe can be divided into various temperature zones from just over 0 °C (32 °F) to an icy -2 °C (28 °F).



### NoFrost

The Monolith also impresses with maximum comfort at sub-zero temperatures. Its NoFrost technology always keeps the freezer compartment free of ice and prevents food from becoming covered in frost. It makes defrosting a thing of the past.



### DuoCooling

DuoCooling technology uses two completely separate refrigeration circuits to prevent air from being exchanged between the fridge and freezer compartments. This protects food in the refrigerator compartment from dry air from the freezer compartment. Also, odours do not mingle and the foods retain their own aroma. There is no air exchange between the fridge and freezer compartments, odour transfer is prevented and stored food does not dry out.



### SuperSilent

Shhh – listen carefully. Your Liebherr is so quiet that you have to strain your ears to hear it. How is this achieved? All refrigeration components such as compressors, valves, fans and evaporators are optimised and perfectly adapted to one another. This means you only hear what you want to hear in your kitchen.



### InfinitySwipe

For a touch more comfort, the user-friendly InfinitySwipe electronic touch control with a bright and clear 3.5-inch display can be operated intuitively and effortlessly via touch & swipe.

# Technical drawing

---

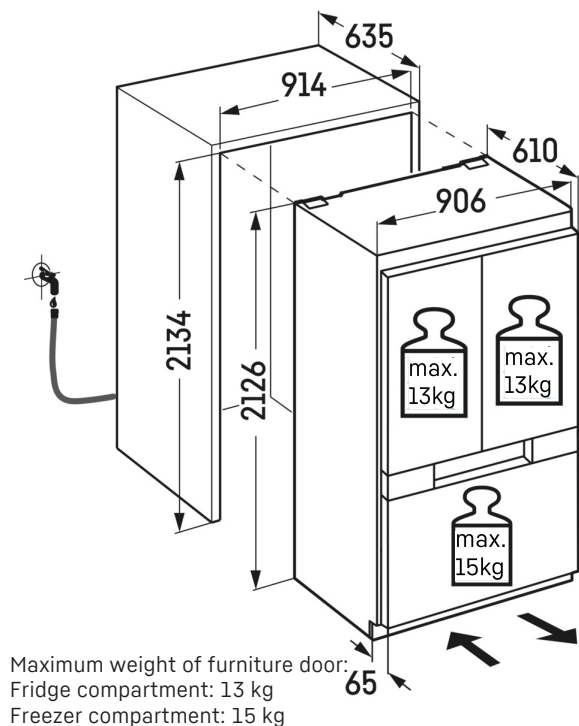

Products and their details are staged for advertising purposes. Whilst every effort is made to ensure all specifications and information in this flyer are accurate, Liebherr reserves the right to make changes without notification. Where actual appliance measurements, specifications, and ratings are crucial, we recommend that the actual appliance installation instructions that accompany each appliance be checked. Liebherr will not be liable for any damage. (21.10.2024)

