

R 9400

Generation 6

LIEBHERR

Mining excavator



Technologies

- Assistance Systems

Powertrain options

Liebherr ICE - Diesel: 1,350 kW (FCO)
1,810 HP
Cummins ICE - Diesel: 1,250 kW (FCO, Tier 4f)
1,675 HP
GE E-Motor: 1,350 kW (50 Hz, 60 Hz)
1,810 HP

Backhoe configuration

Overall weight: 345 tonnes
380 tons
Bucket payload: 43.5 tonnes
48 tons

Face shovel configuration

Overall weight: 353 tonnes
380 tons
Bucket payload: 40 tonnes
44 tons

Overview
R 9400





Diesel drive 1,350 kW / 1,810 HP
Electric drive 1,350 kW / 1,810 HP



BH 24 m³ / 31.4 yd³
FS 22 m³ / 28.8 yd³



BH 345 tonnes / 380 tons
FS 353 tonnes / 389 tons



Performance

Productive, efficient and reliable





The R 9400 is built to outperform all competitors in the medium class mining market. Boasting a 24.0m³ / 31.4yd³ bucket capacity in standard configuration, the R 9400 is the ideal machine to load a fleet of 140–240 t mining trucks. Available in both diesel or electric versions, the R 9400 offers the flexibility to perform many specific applications.

Fast and precise movement

Powerful drive system

The R 9400 can be fitted with two versions of diesel ICE. Customers can choose between the Liebherr D9812 and the Cummins QSK50 ICE, both have been specifically adapted to withstand the most extreme environments and to reach the highest uptime performance for maximum productivity. The electric drive system provides superior performance when the machine is used in the toughest of conditions.

Fast cycle time

Rather than using a standard open hydraulic circuit, the R 9400 employs a closed-loop swing circuit, enabling maximum swing torque while retaining the full oil flow for the working circuit. The independent swing circuit in combination with the powerful drive system leads to fast arm motion, contributing to faster cycle times.

Precise machine motions

The R 9400 design integrates the Litronic Plus electronic control system allowing for easy control even when simultaneous movements are required. The patented Liebherr electronic damping system provides controlled end-cushioning for smooth attachment motions.

High digging and lifting capabilities

High digging forces & power-oriented energy management

Designed for the best mechanical force distribution, the production-tailored attachment delivers increased digging and lifting forces. Integrating Liebherr-made cylinders and a wide range of buckets with mining-optimized GET, the R 9400's attachment ensures the highest forces, easy bucket penetration and high fill factor to perform even in the most demanding conditions.

Engine / motor options

Diesel engine:

- Cummins QSK50 US EPA Tier 4f / EU Stage V compliant
- Fuel consumption optimized version for Liebherr or Cummins engines

Electric drive (optional):

- 3 phase AC squirrel cage motor
- Voltage on request
- 50 or 60 Hz frequency

Electronic cylinder damping system

- Patented system based on electronic control
- Controlled end-cushioning for smooth attachment motions
- Allows the operator to focus on loading
- Intelligent energy management
- Increase of cylinders reliability

High performance execution

An innovative attachment solution to improve cost per tonne, maximize machine productivity / truck utilization without any compromise in structural / component life and cycle time:

- Use of Smart Components Design to reduce total weight, increasing bucket payload and reinforcing bucket wear protection for extended lifetime (GP, HD, XHD)
- Maximized loading capacity thanks to Liebherr Bucket Solution and patented EVO design

The R 9400 follows the Liebherr design philosophy of maximizing a machine's performance by improving the efficiency of all individual subsystems. Engineered for easy serviceability the machine is designed to ensure maximum uptime. The R 9400's spacious cab creates a comfortable working environment, ensuring peak operator performance at every shift.



Built for maximum profitability

Electro-hydraulic system efficiency

Liebherr hydraulic technology in combination with the precision of electronic control contributes to the R 9400's efficient use of energy. The high-pressure hydraulic system and the optimized pipe and hose layout maximize usable power transmission. Hydraulic pumps are electronically managed to provide optimal pressure compensation and oil flow management. The hydraulic system is independently regulated over the engine circuit for the best operational efficiency.

Independent cooling system

Oil and water cooling fans are independent and electronically managed. The on-demand cooling control provides efficient power for the working process. This technology contributes to maintaining sustainable temperature of all hydraulic components, extending their life.

Closed loop swing circuit

All Liebherr mining excavators are equipped with a closed loop swing circuit. Kinetic energy can be saved when the swing motion is used during deceleration, to drive the main and auxiliary pumps, reducing fuel consumption.

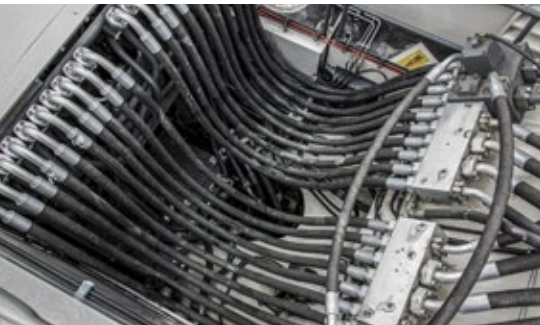

Hydraulic system efficiency

The R 9400's hydraulic system is designed for an optimized hydraulic power management via the:

- Closed-loop swing circuit
- Pressureless boom down function
- Electronic hydraulic pumps management
- High pressure hydraulic oil filtration system
- Electro-hydraulic control system
- Optimized pipe and hose layout



Central service station

The service flap is hydraulically actuated and accessible from the ground level allowing for fast maintenance:

- Hydraulic oil
- Engine oil
- Splitter box oil
- Swing gearbox oil
- Attachment / swing ring bearing grease with filters
- Swing ring teeth grease with filter
- Windshield water
- Fuel (non-pressurised refueling system in option)

Comfortable cab for efficient work

The large and spacious cab provides ideal working conditions and optimal operator's comfort. Mounted on silent blocks, the cab design reduces vibrations and limits noise pollution to provide a quiet working environment.

Extended components lifetime

The R 9400's hydraulic oil filtration systems remove fluid contaminants to offer the highest rate of hydraulic components durability. To maintain oil quality, all return hydraulic oil flow goes through a fine filtration system (15/5 µm) and oil tank is sized to considerably extend the time between service intervals.



Comfort-oriented cab design

- Tinted laminated safety glass
- Armored front and attachment side windows
- Heavy duty sun louvers
- Adjustable air suspended seat
- Pressurised A/C system
- Pressurization to prevent dust penetration
- Trainer's seat

IoMine

Unleash the full potential of your mine.



Your connected mining ecosystem

IoMine, Liebherr Mining's cutting-edge technology product line, supports customers' transition to integrated operations. By adopting IoMine, customers can improve decision-making and provide greater operational safety – all while fostering sustainable development and ensuring cost optimisation in the management of their mines. IoMine is a reliable partner for achieving a more efficient, cost-effective, and productive mining operation.

Partnering for mining success

IoMine, Liebherr Mining's advanced technology product line, optimises operations by improving asset availability, efficiency and productivity. These products enhance fleet capabilities, simplify operations and improve fleet management for more profitability and smarter energy use.

Unlock peak performance



Enhanced decision-making

Optimise your mining operations and increase efficiency by making informed decisions supported by accurate, real-time data.



Increased safety

Real-time machine monitoring and operator alerts from assistance systems enhance safety while autonomous technology reduces risks, ensuring a safer worksite.



Increased operational efficiency

Real-time operator assistance, streamlined maintenance and autonomous technologies work together to enhance integration, productivity, efficiency and profitability.



Maximised machine availability

Proactive maintenance, operational insights and advanced automation collectively prevent breakdowns, minimise downtime and boost efficiency, productivity and profitability for continuous operations.





Let's journey together on the path to data-driven decision-making and autonomy in digging, dozing and hauling.



Operate – Empower mining success.

Find the right IoMine products dedicated to operations to optimise processes, reinforce safety and increase the profitability of your mining operations.



Automate – Safe. Efficient. Automated.

Liebherr's advanced automation solutions integrate seamlessly into your existing systems for real-time monitoring and intelligent automation.



Maintain – Less downtime, more mining.

Keep your mining fleet running at peak performance with IoMine's dedicated maintenance products, whose innovative maintenance solutions are designed to minimise downtime and increase efficiency.



Quality

The Liebherr

trademark

With over 50 years of innovative thinking, engineering and manufacturing excellence, Liebherr sets the industry standard for advanced equipment design and technology tools to provide the most up-to-date product, responding to requirements of mining customers.

Long-lasting job performances

Maximized components lifetime

The R 9400 is equipped with an automatic single line lubrication system for the entire attachment and swing ring. All greasing points are suitably protected against external damages, extending component life and ensuring constant performance over the excavator's operational life.

Rugged undercarriage structure

The R 9400 is mounted on a heavy duty fatigue resistant undercarriage. The swing ring is reinforced to provide an improved superstructure weight distribution. Designed and built for both shovel and backhoe configurations, the enlarged undercarriage offers an efficient ground bearing pressure management providing the necessary stability and reliability.

Liebherr components integration

As an OEM, Liebherr has built a solid reputation for its development and production of high quality strategic mining components. The R 9400 integrates robust and reliable mining optimized components that are developed, manufactured and controlled by Liebherr ensuring reliable performance for the entire machine.

Machine reliability survey

Based on years of experience and the systematic measurement of key performance indicators of the machine behavior in the field, the Liebherr Mining Reliability Engineering Group is constantly seeking new ways to enhance reliability.

Quality management continuous improvement

Liebherr quality begins during machine design and simulations. Liebherr meets the highest standards for special selections of steels and casting materials. Based on the expertise of certified internal auditors and a highly qualified workforce, all manufacturing process steps are devised to provide the most comprehensive control, monitoring and traceability. Liebherr-Mining Equipment Colmar SAS is ISO 9001 certified.



Arctic package (optional)

Designed for reliability in regions with extreme temperatures:

- Integrated into machine structure
- Start up easily even at very low temperatures
- Increases machine availability and components lifetime
- Optimum operator comfort even in harsh temperature conditions
- Facilitate machine servicing

Strengthened attachment design

Backhoe or face shovel attachments are built to face all standard and specific applications:

- Use of advanced welding techniques
- Reinforced with strategically located castings in high stress areas
- Heat treatment to reduce residual stresses and increase fatigue life
- Designed for maximum structure life
- Use of cutting-edge engineering tools such as Finite Element Analysis and Fatigue Life Analysis

Quality commitment

- Liebherr-Mining Equipment Colmar, France, ISO 9001 certified
- Compliance of materials tested in laboratory
- Quality control during the stages of production
- Vertical integration practice
- CE certified (2006/42/EC), MDG 15 and MDG 41 compliant

Service

Where you need it, when you need it

By partnering with our customers, Liebherr implements tailored solutions from technical support, spare parts and logistics solutions to global maintenance for all types of equipment, all over the world.



Liebherr service tools

Liebherr delivers a wide range of service tools for excavator-specific maintenance ensuring optimal working conditions no matter the size of the component.

- An OEM-certified solution
- Maximized machine uptime
- Cost-efficient maintenance
- Easy machine serviceability
- Uncompromising operational safety



The Liebherr-Mining remanufacturing program

- Liebherr certified quality
- As-new warranty
- OEM expertise
- Reduced costs and investment
- Fast availability



MyLiebherr customer portal

- Easy access parts online
- Available any time anywhere
- User friendly interface
- Online ordering
- Save time and money



Customer support

International service organization

The Liebherr Service Support has always been an important focus for the company. Complete service during all operating phases from machinery installation to problem solving, spare parts inventory and technical service. Our service team is close to our customers, delivering the best specific maintenance solution to reduce both equipment downtime and repair costs.

Complete training programs

The Liebherr mining training system provides blended training sessions for operator and maintenance staff to encourage productive, cost-effective and safe mining operation. The Liebherr mining training system employs online learning programs, factory and on-site sessions and simulator training.

Remanufacturing

Reduced costs and investment

Over the course of a mining machine's lifetime, major components must be replaced to ensure continued safety, productivity and reliability. The Liebherr mining remanufacturing program offers customers an OEM alternative to purchasing brand new replacement components. Enabling customers to achieve lowest possible equipment lifecycle costs without compromising quality, performance or reliability.

Fast availability

A international service network and component facilities worldwide means that component repair services and exchange components are available to customers regardless of their location.

Genuine parts

Performance

Using genuine Liebherr components ensures the best interaction within your machine, encouraging optimal performance and most effective machine operation. For all major components, Liebherr relies on its Liebherr maintenance management system to follow and monitor service life while predicting maintenance activities.

Partnership

Liebherr regularly reviews requirements for parts and components for individual machines, based on operating hours, consumption and planned maintenance, resulting in minimized down time for customers. With access to the global stock via all Liebherr mining warehouses, you will improve productivity by having the part you need, when you need it.

Safety

Protecting your most important assets

The Liebherr R 9400 provides uncompromising safety for operators and maintenance crews. Equipped with the service flap accessible from the ground level and integrating wide open accesses, the R 9400 allows quick and safe maintenance. The R 9400's cab provides numerous features for operator safety.



Safety-first working conditions

Safe service access

The R 9400 is fitted with ergonomic access for fast and safe maintenance. All service points are within reach from one side and at machine level. The R 9400's upperstructure is accessible via a robust fixed ladder or via an optional hydraulic actuated 45° stairway.

Secure maintenance

All components have been located to allow for effortless inspection and replacement. Numerous service lights are strategically located in the service areas to sustain suitable maintenance conditions, day or night. Emergency stops have been strategically placed in the cab, engine compartment and at ground level. The R 9400 eliminates hazards to ensure a safe environment for the service staff during maintenance.

Efficient machine protection

Protection against fire ignition

The engine compartment integrates a bulkhead wall that separates the engine from the hydraulic pumps. This reduces the risk of hydraulic oil entering the engine compartment. The turbochargers and exhaust systems are heat shielded, and all the hydraulic hoses are made from a fire resistant material.

Automatic fire suppression system

The R 9400 can be equipped with a fully integrated fire suppression, employing a dual agent solution to prevent and protect the machine. The fire suppression system has both automatic and manual release capabilities. E-stops, interconnected with the fire suppression system, are strategically located in the cab, over the machine, on the ground level to be easily accessible in any case by the operator or maintenance. The automatic fire suppression system is connected to the machine electronic, in case of release, the 45° access stairway is automatically activated.



User friendly maintenance

The machine is easily visible even by night or in extremely dusty working environments thanks to:

- 12 long-range working LED lights located on attachment, upper-carriage and counterweight
- Travel alarm system with light and buzzer



Machine access

Designed for safe access on the machine upperstructure via:

- A 45° powered stairway and catwalks with handrails and perforated steps
- Walkways with slip-resistant surfaces
- Emergency egress with handrails in front of the excavator



Commitment to employees safety

- Safe and protected access to the components
- Major components centralized to be easily accessible
- E-stops located for the operator and maintenance staff
- Ground-level fluid maintenance hub
- Rear and side vision system

Sustainability
Committed to our future



Reman

The Liebherr-Mining remanufacturing program

- Second life for your components
- Liebherr certified workshops
- Reduced environmental impact
- Reduced costs and investment
- Alternative to purchase brand-new replacement components

Electric drive version

The electric drive system is an efficient alternative to diesel engine allowing:

- Less vibration resulting in higher component lifetime
- Lower maintenance costs
- Less noise pollution
- No exhaust gas emissions
- High motor efficiency
- Maximum efficiency in cold climate conditions when combined with the arctic package



Liebherr considers the conservation and preservation of the environment as a major challenge for the present and future. Liebherr are considerate of environmental issues in designing, manufacturing and managing machine structures, providing solutions that allow customers to balance performance with environmental consciousness.

Minimized environmental impact

Optimized energy consumption, fewer emissions

The intelligent energy management system facilitates interaction between the hydraulic system and engine output with the goal of maximum performance with minimum consumption. In “Eco-Mode” setting, the machine is set up to reduce engine load, significantly improve fuel consumption and reduce emissions.

Controlled emission rejection

The R 9400 is available with Cummins engine that comply with US EPA Tier 4f/ EU Stage V emission limits. This power drive makes the R 9400 cost effective without compromising productivity and reduces the machines impact on the environment.

Sustainable design and manufacturing process

Certified environment management systems

Subject to the stringent European program for the regulation of the use of chemical substances in the manufacturing process (REACH*), Liebherr undertakes a global evaluation to minimize the impacts of hazardous material, pollution control, water conservation, energy and environmental campaigns.

Extended components and fluids lifetime

Liebherr is constantly working on ways to extend component life. Through the exchange components program, superior lubrication systems and the reinforcement of parts under stress, Liebherr can reduce frequency of part replacement. The result minimizes environmental impact and lowers the overall total cost of ownership.



*REACH is the European Community Regulation on chemicals and their safe use (EC 1907 / 2006). It deals with the registration, evaluation, authorization and restriction of chemical substances.



Future proof

One modular platform, many possibilities

Liebherr has a modular design approach for its largest excavators. The company's engineers follow this approach from the earliest stages of machine design when developing our e-drive powerpack and internal combustion engines (ICE).



Modular maintenance

Liebherr's modular maintenance program offers customers an opportunity to optimise the replacement of major component assemblies (modules). This program effectively delivers required maintenance for mobile equipment while minimising downtime, maximising efficiencies and improving overall safety.

Reduce
downtime
by up to **50 %**

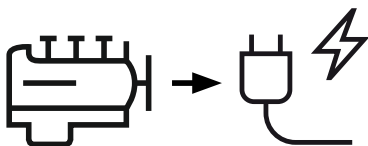

Repowering from internal combustion engine to electric

Customers can convert their diesel-powered Liebherr excavators to electric drive with our repower solutions as Liebherr's diesel-powered and electric-drive excavators share 70% component commonality. Further, these repowers can be carried out during major overhauls of the excavators, meaning that they can be upgraded throughout their lives to meet customers' evolving decarbonisation strategies.

Decarbonise



**your mining
operations**





Retrofit solutions

Liebherr retrofits are the right solution for customers wanting to upgrade their equipment by adding new features and/or products. They enable customers to:

- Flexibly upgrade their equipment to make it future proof
- Implement assistance systems that provide insights for operational decision-making and safety
- Comply with regulatory emission requirements and standards

***Unlock the full potential
of your excavator***

For more information, please contact your local Liebherr sales and service company or sales partner.

The four pillars of the Liebherr mining division

With more than 50 years of experience in the mining industry, Liebherr has identified four key factors of customer satisfaction: Performance, Safety, Service, and Sustainability. These pillars provide structure and focus for all our activities, and embody Liebherr's customer commitments.





Performance
Productive, efficient and reliable



Safety
Protecting your most important assets



Service
Where you need it, when you need it



Sustainability
Committed to our future



Technical data

Powertrain

1 Liebherr ICE – Diesel	
Rating per ISO 3046	1,350 kW (1,810 HP) at 1,500 rpm
Model	D9812 (Fuel consumption optimized setting)
Type	12 cylinder V-engine
Bore / Stroke	175 / 215 mm / 6.89 / 8.46 in
Displacement	62l / 3,786 in ³
Alternator	24 V / 370 A
or	
1 Cummins ICE – Diesel	
Rating per SAE J1995	1,250 kW (1,675 HP) at 1,800 rpm
Model	Cummins QSK50 (US EPA Tier 4f / EU Stage V compliant or fuel consumption optimized setting)
Type	16 cylinder turbocharged V-engine after-cooler separate water cooling circuits common-rail
Bore / Stroke	159 / 159 mm / 6.26 / 6.26 in
Displacement	50.3l / 3,069 in ³
Engine cooling system	fans driven via hydraulic piston motor
Air cleaner	dry-type air cleaner with pre-cleaner, with automatic dust ejector, primary and safety elements
Fuel tank capacity	6,908l / 1,825 gal
DEF tank capacity	665l / 176 gal
Electrical system	
Voltage	24 V
Batteries	4 x 180 Ah / 12 V service systems
Alternator	24 V / 260 A
Engine idling	automatic engine idling
Electronic engine power management	engine power and speed sensing over the entire engine rpm range
or	
1 GE E-Motor	
Power output	1,350 kW (1,810 HP)
Type	3-phase AC squirrel cage motor
Voltage	6,000 V, other voltage on request
Frequency	50 Hz (or 60 Hz)
Revolutions	1,500 rpm or 1,800 rpm
Motor cooling	integrated air-to-air heat exchanger
Starting method	inrush current limited to 2.2 full load current

Electro-hydraulic controls

Servo circuit	independent, electric over hydraulic proportional controls of each function
Emergency control	via accumulator for all attachment functions with stopped engine
Power distribution	via monoblock control valves with integrated primary relief valves and flanged on secondary valves
Flow summation	attachment and travel drive
Control functions	
Attachment and swing	proportional via joystick levers
Travel	proportional via foot pedals or hand levers
Bottom dump bucket	proportional via foot pedals

Swing drive

Hydraulic motor	2 Liebherr axial piston motors
Swing gear	2 Liebherr planetary reduction gears
Swing ring	Liebherr, sealed triple roller swing ring, internal teeth
Swing speed	0–3.9 rpm
Swing-holding brake	hydraulically released, maintenance-free, multi-disc brakes integrated in each swing gear

Hydraulic system

Hydraulic pump for attachment and travel drive	4 variable flow axial piston pumps
Max. flow	4 x 751 l/min. / 4 x 198 gpm
Max. pressure for swing drive	320 bar / 4,640 psi
Max. flow	2 reversible swashplate pumps, closed-loop circuit
Max. pressure	2 x 390 l/min. / 2 x 103 gpm
Pump management	350 bar / 5,076 psi
Hydraulic tank capacity	electronically controlled pressure and flow management with oil flow optimisation
Hydraulic system capacity	2,200 l / 581 gal
Hydraulic oil filter	4,200 l / 1,110 gal
Hydraulic oil cooler	1 high pressure safety filter after each main pump + fine filtration of entire return flow (15 / 5 µm)
	2 separate coolers, 2 temperature controlled fans driven via hydraulic piston motor

Electric system

Electric isolation	easy accessible battery isolations
Working lights	high brightness LED lights: – 4 on working attachment – 2 on cabin – 3 on RHS of uppercarriage – 3 on LHS of uppercarriage
Emergency stop switches	at ground level, in hydraulic compartment, in engine compartment, at valve bank and in operator cab
Electrical wiring	heavy duty execution in IP 65 standard for operating conditions of –50°C to 100°C / –58°F to 212°F

Uppercarriage

Design	torque resistant designed upper frame in box-type construction for superior strength and durability
Attachment mounting	parallel longitudinal main girders in box section construction
Machine access	45° access system with handrails on the cab side of the uppercarriage, full controlled descent, in case of emergency stop additional emergency ladder fitted near the cab

Cab

Design	resiliently mounted, sound insulated, large windows for all around visibility, integrated falling object protection FOPS (ISO 10262)
Operator's seat	suspended, body-contoured with shock absorber, adjustable to operator's weight
Cabin windows	20.5mm / 0.8in tinted armored glass for front window and 18mm / 0.7in for right-hand side windows, all other windows in tinted safety glass, high pressure windshield-washer system 75l / 20gal watertank, aluminium sun louvers on all windows
Heating system / Air conditioning	heavy duty, fully automatic, high output air conditioner and heater unit, contains fluorinated greenhouse gases HFC 134a with a Global Warming Potential (GWP) of 1430, the AC circuit contains 8.0 kg / 17.6 lb of HFC-134 representing an equivalent of 11.4 tonnes / 12.6 tons of CO ₂ , the 2 nd AC circuit (optional) contains 4.8 kg / 10.6 lb of HFC-134 representing an equivalent of 6.9 tonnes / 7.6 tons of CO ₂
Cabin pressurization	ventilation with filter, minimum pressurization of 50 Pa (ISO 10263-3)
Controls	joystick levers integrated into armrest of seat
Monitoring	via LCD-display, data memory
Rear vision system	camera installation on counterweight and right-hand side of the uppercarriage, displayed over an additional LCD-display
Automatic engine shut off	engine self-controlled power limitation and shut off
Destroking of main pumps	in case of low hydraulic oil level
Safety functions	additional gauges with constant display for: engine speed, hourmeter, voltmeter, safety mode for engine speed control and pump regulation
Noise level (ISO 6396)	Diesel: L _{PA} (inside cab) = 78 dB(A)
Hand-arm vibrations	≤ 2.5 m/s ²
Whole-body vibrations	≤ 0.5 m/s ²

Undercarriage

Design	3-piece undercarriage, box-type structures for center piece and side frames (stress relieved steel work component as a standard)
Hydraulic motor	2 axial piston motors per side frame
Travel gear	Liebherr planetary reduction gear
Travel speed	0-2.7 km/h / 0-1.67 mph
Parking brake	spring engaged, hydraulically pressure released external wet multi-disc brakes for each travel motor, maintenance-free
Track components	maintenance-free, forged double grouser pad, tractor-type chain, optional maintenance-free dual pin cast link and pad combined
Track rollers / Carrier rollers	9 / 2 per side frame
Track tensioner	pressurized hydraulic cylinder with accumulator and grease adjuster
Transport	undercarriage side frames are removable

Service flap

Design	hydraulically actuated service flap, with lighting easily accessible from ground level to allow: <ul style="list-style-type: none"> - fuel fast refill - hydraulic oil refill - engine oil quick change - splitterbox oil quick change - swing gearbox oil quick change - swing ring teeth grease barrel refilling via grease filter - attachment / swing ring bearing grease barrel refilling via grease filter - windshield wash water refilling - other coupler type on request
--------	---

Central lubrication system

Type	single-line lubrication system, for the entire attachment / swing ring bearing and teeth
Grease pumps	1 hydraulic grease pump for the attachment / swing ring bearing and 1 hydraulic grease pump for swing ring teeth
Capacity	200l / 53 gal bulk container for attachment / swing ring bearing, separated 80l / 21 gal bulk container for swing ring teeth
Refill	via the service flap for both containers, fill line with grease filters

Attachment

Design	box-type structure with large steel castings in all high-stress areas
Stick	wear protection underneath lower beam plate
Pivots	sealed with double side centering with 1 single floating pin per side, all bearings with wear resistant steel bushings, bolts hardened and chromium-plated
Hydraulic cylinder	Liebherr design and made, all cylinders located in well protected areas
Hydraulic connections	pipes and hoses equipped with SAE split-flange connections
Pivots bucket-to-stick Pivots bucket-to-link	O-ring sealed and completely enclosed
Lubrication	connected to the centralized lubrication system, each lubrication point independently lubricated
Kinematics	Liebherr parallel face shovel attachment geometry, backhoe bucket pivoting angle 150°, electronic controlled end-cushioning

Dimensions

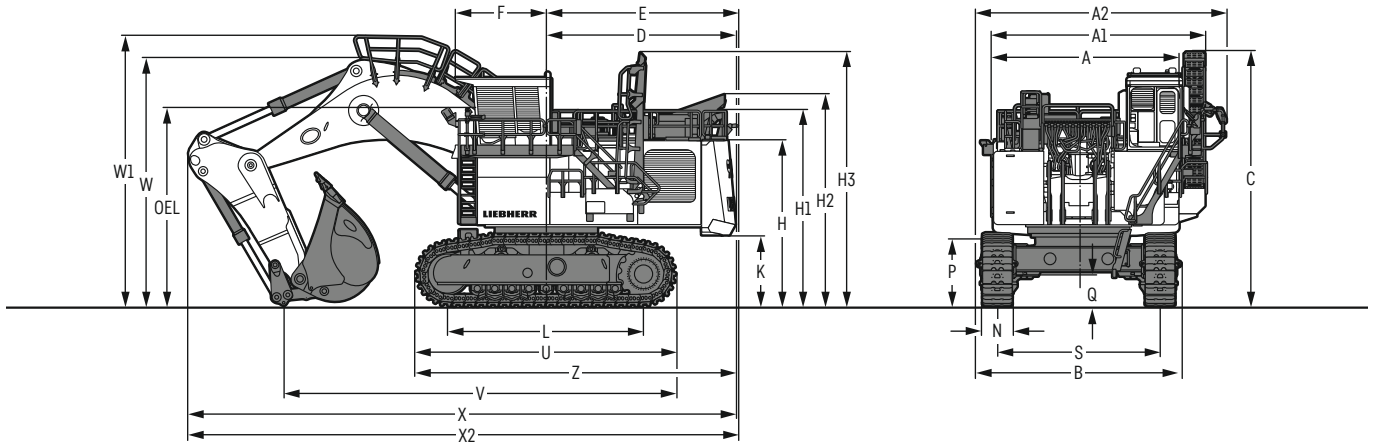

	mm / ft in		mm / ft in		mm / ft in		mm / ft in
A	6,300 / 20' 8"	F	3,090 / 10' 2"	N	1,000 / 3' 3"	W1	9,250 / 30' 4"
A1	8,350 / 27' 5"	H	5,615 / 18' 5"	P	3,000 / 9'10"	X	18,530 / 60'10"
A2	8,520 / 27'11"	H1	6,600 / 21' 8"	Q	1,190 / 3'11"	X2	18,630 / 61' 1"
B	6,930 / 22' 9"	H2	7,175 / 23' 6"	S	5,520 / 18' 1"	Z	10,840 / 35' 7"
C	8,045 / 26' 5"	H3	8,585 / 28' 2"	U	8,800 / 28'10"	OEL (Operator's eye level)	6,740 / 22' 1"
D	6,400 / 20'11"	K	2,385 / 7'10"	V	13,280 / 43' 7"		
E	6,700 / 22'	L	6,645 / 21'10"	W	8,420 / 27' 7"		

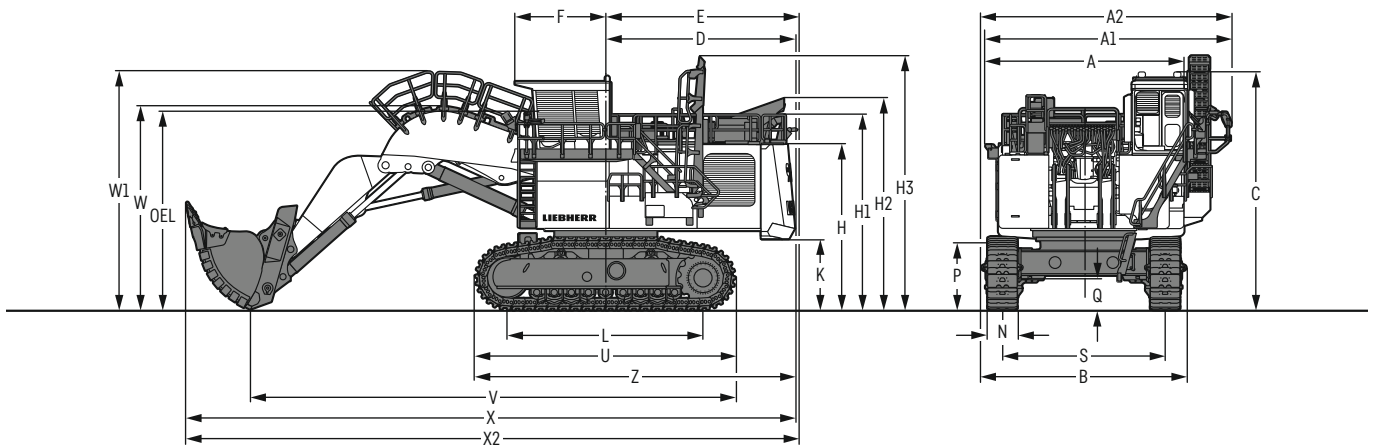

	mm / ft in		mm / ft in		mm / ft in		mm / ft in
A	6,300 / 20' 8"	F	3,090 / 10' 2"	N	1,000 / 3' 3"	W1	8,120 / 26' 8"
A1	8,350 / 27' 5"	H	5,615 / 18' 5"	P	3,000 / 9'10"	X	20,620 / 67' 8"
A2	8,520 / 27'11"	H1	6,600 / 21' 8"	Q	1,190 / 3'11"	X2	20,720 / 68'
B	6,930 / 22' 9"	H2	7,175 / 23' 6"	S	5,520 / 18' 1"	Z	10,840 / 35' 7"
C	8,045 / 26' 5"	H3	8,585 / 28' 2"	U	8,800 / 28'10"	OEL (Operator's eye level)	6,740 / 22' 1"
D	6,400 / 20'11"	K	2,385 / 7'10"	V	16,430 / 53'11"		
E	6,700 / 22'	L	6,645 / 21'10"	W	6,930 / 22' 9"		

According to ISO 9248, measurements of general machinery dimensions, performances and capacities may vary within tolerances given by this norm.

Backhoe attachment

with mono boom 9.30 m / 30'6"

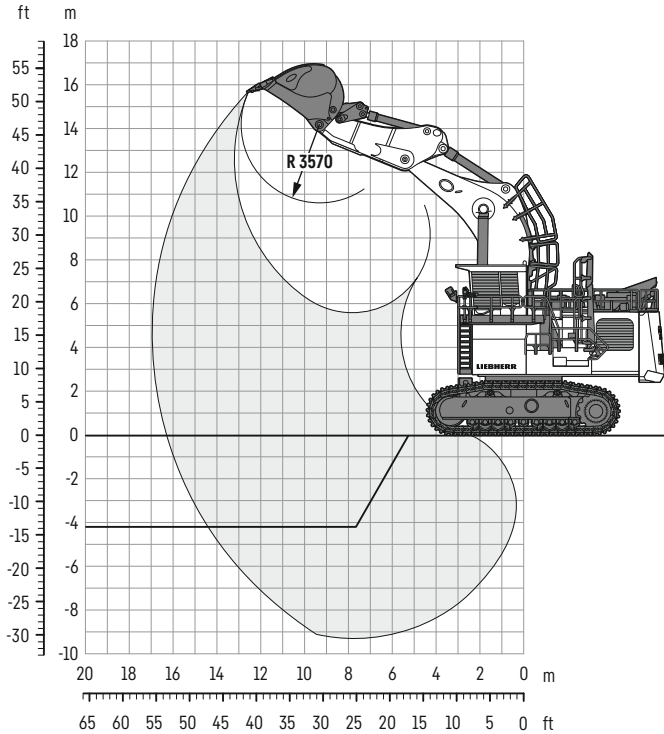

Digging envelope

Stick length	m	4.20
	ft in	13'9"
Max. digging depth	m	9.30
	ft in	30'5"
Max. reach at ground level	m	16.30
	ft in	53'5"
Max. dumping height	m	10.60
	ft in	34'8"
Max. teeth height	m	15.70
	ft in	51'5"

Forces

Max. digging force (ISO 6015)	kN	965
	lbf	216,940
Max. breakout force (ISO 6015)	kN	1,000
	lbf	224,809

Machine shown without option with a bucket for average material abrasiveness and 1.8t/m³ (3,034 lb/yd³) density.

The characteristics of the material to be extracted and additional options can change the bucket volume, its shape, its radius and therefore may also change the work area reachable by the bucket.

Operating weight and ground pressure

The operating weight includes the basic machine with backhoe attachment and backhoe bucket 24.00 m³ / 31.4 yd³.

Pad width	mm	1,000
	ft in	3'3"
Weight	kg	345,500
	lb	760,600
Ground pressure*	kg/cm ²	2.33
	psi	33.11

* according to ISO 16754

Backhoe buckets

For materials class according to VOB, Section C, DIN 18300	<5	5-6	5-6	5-6	7-8	7-8
Typical operation according to VOB, Section C, DIN 18300	GP	HD	HD	HD	XHD	XHD
Capacity ISO 7451	m ³	26.00	20.00	24.00	26.00	20.70
	yd ³	34.0	26.2	31.4	34.0	27.1
Suitable for material up to a specific weight of	t/m ³	1.7	2.2	1.8	1.6	2.0
	lb/yd ³	2,867	3,710	3,035	2,698	3,373
Cutting width	mm	3,900	3,400	3,700	3,900	3,700
	ft in	12'9"	11'1"	12'1"	12'9"	12'1"
Weight	kg	20,500	20,700	21,500	22,300	23,000
	lb	45,195	45,636	47,400	49,163	50,706

GP: General purpose bucket with Liebherr Z14 teeth

HD: Heavy-duty bucket with Liebherr Z14 teeth

XHD: Heavy-duty rock bucket with Liebherr Z14 teeth

According to ISO 9248, measurements of general machinery dimensions, performances and capacities may vary within tolerances given by this norm.

Face shovel attachment

with shovel boom 6.75 m / 22'1"

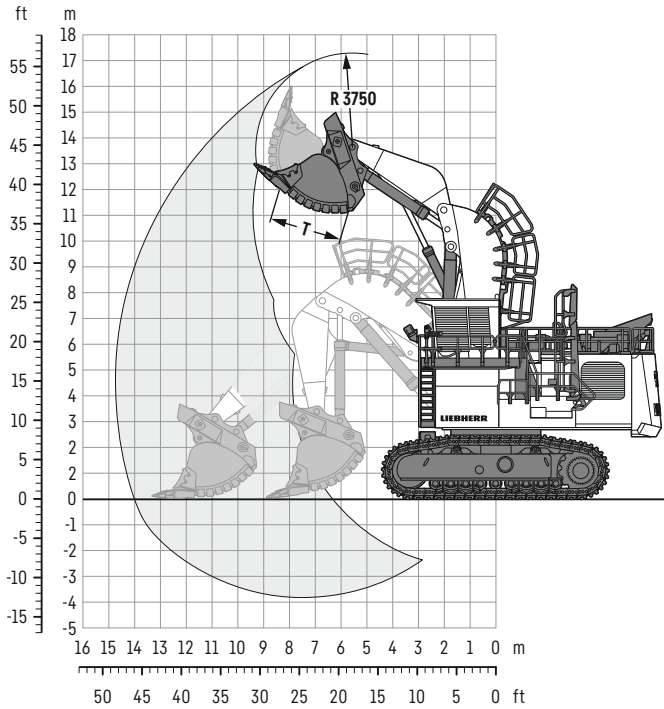

Digging envelope

Stick length	m	4.30
	ft in	14'1"
Max. reach at ground level	m	14.00
	ft in	45'11"
Max. dumping height	m	11.20
	ft in	36'8"
Max. crowd length	m	4.50
	ft in	14'9"
Bucket opening width T	m	2.50
	ft in	8'2"

Forces

Max. crowd force at ground level (ISO 6015)	kN	1,145
	lbf	257,406
Max. crowd force (ISO 6015)	kN	1,545
	lbf	347,330
Max. breakout force (ISO 6015)	kN	1,195
	lbf	268,646

Machine shown without option with a bucket for average material abrasiveness and 1.8t/m³ (3,034 lb/yd³) density.

The characteristics of the material to be extracted and additional options can change the bucket volume, its shape, its radius and therefore may also change the work area reachable by the bucket.

Operating weight and ground pressure

The operating weight includes the basic machine with shovel attachment and bucket 22.00m³ / 28.8yd³.

Pad width	mm	1,000
	ft in	3'3"
Weight	kg	353,000
	lb	778,200
Ground pressure*	kg/cm ²	2.38
	psi	33.83

* according to ISO 16754

Face shovel buckets

For materials class according to VOB, Section C, DIN 18300	<5	<5	5-6	5-6	7-8	7-8
Typical operation according to VOB, Section C, DIN 18300	GP	GP	HD	HD	XHD	XHD
Capacity ISO 7451	m ³ yd ³	24.00 31.4	22.00 28.8	18.00 23.5	22.00 28.8	18.00 23.5
Suitable for material up to a specific weight of	t/m ³ lb/yd ³	1.6 2,698	1.8 3,035	2.2 3,710	1.8 3,035	2.1 3,541
Cutting width	mm ft in	4,250 13'11"	4,250 13'11"	4,250 13'11"	4,250 13'11"	4,250 13'11"
Weight	kg lb	36,700 80,910	35,400 78,044	35,400 78,044	35,400 78,044	37,500 82,673
						38,500 84,878

GP: General purpose bucket with Liebherr Z14 teeth

HD: Heavy-duty bucket with Liebherr Z14 teeth

XHD: Heavy-duty rock bucket with Liebherr Z14 teeth

According to ISO 9248, measurements of general machinery dimensions, performances and capacities may vary within tolerances given by this norm.

Optional equipment

Undercarriage

Monoblock chain system
Undercarriage bottom cover
Rock protection for idler wheel

Uppercarriage

Banlaw fast fueling system
Fueling system with Multiflo Hydra-Flo®
Wiggins/Banlaw counter plugs for fuel/lube trucks
Slewing ring with 90° installation arrangement
Swing ring scrapers

Hydraulic system

Oil cooler inlet screen

Powertrain

Fuel consumption optimized engine version (non-certified)
Automatic engine shutdown timer (5 min.)
Cummins Eliminator™ kit

Cab

4-point seat belt
Additional back and side wipers
Double A/C system
Front protective grid
Sliding window
Auxiliary cab heating system

Attachment

Piston rod guard for bucket cylinder (BH)

Specific solutions

Arctic package (different stages available)
High altitude package

Safety

Automatic fire suppression system
Isolation & energy dissipation system - MDG 41 compliant

General

Maritime transport packaging

E-drive

Automatic cable reel

IoMine

Truck Loading Assistant
Operational Analytics



Mining excavator



Mining truck



Mining dozer



Mining dragline



Service tools



Customer service

Quality commitment

- Liebherr-Mining Equipment Colmar, France, ISO 9001 certified
- Compliance of materials tested in laboratory
- Quality control during all stages of production
- CE certified, MDG 15 & MDG 41 compliant

Subject to technical modifications. All comparisons and claims of performance are made with respect to the prior Liebherr model unless specifically stated.

Liebherr-Mining Equipment Colmar SAS

49 rue Willi Liebherr • 68025 Colmar Cedex, France • Phone +33 369 4920 00
info.lec@liebherr.com • www.liebherr.com • www.facebook.com/LiebherrMining